

**Course Structure & Syllabus of B.Tech.– Petroleum Engineering
Applicable for Batch: 2021-25**

DIT UNIVERSITY

Dehradun



Detailed Course Structure & Syllabus

of

B.Tech. – Petroleum Engineering

(Fully Flexible Choice Based Credit System)

Course Structure & Syllabus of B.Tech.– Petroleum Engineering

Applicable for Batch: 2021-25

Introduction

The Ministry of Human Resource Development (MHRD), Govt. of India, has initiated development of a New Education Policy (NEP) to bring out comprehensive reforms in the Indian education system.

The University Grants Commission (UGC) has subsequently initiated several steps to foster academic excellence through introduction of paradigm shift in learning and teaching pedagogy, innovation and improvement in course curricula, examination and education system.

While a majority of education institutions have started following the semester-based system of education, it has been observed that this new system is still producing graduates who lack knowledge, values, skills and are not job ready professional. The reason for this lacking could be attributed to the rigidity of our program structures and lack of flexibility to have choices among core subject education, liberal arts, ability enhancement, skill development, etc., that is fundamental to overall development and employability of these graduates.

To make this possible, a fully flexible choice-based credit system (FFCBCS), a well-established internationally known system, is proposed. This fully flexible choice-based credit system allows students the flexibility to learn at their own pace, and register for both core subjects and a variety of courses from other areas, leading to holistic development of an individual. The FFCBCS will facilitate us to bench mark our programs with best international liberal arts based academic programs.

Advantages of the FFCBCS structure:

- Shift in focus from the teacher-centric to student-centric education. Student can curve out their program structure by choosing minimum number of credits from well-defined baskets.
- Student may undertake as many credits as they can cope with.
- FFCBCS allows students to choose courses from various baskets of inter-disciplinary, intra-disciplinary, skill oriented, ability enhancing, and from other disciplines.

Features unique to DIT University FFCBCS structure

1. A minimum of 150-160 credits has to be earned by a student to be eligible for an Under Graduate degree in Engineering. Each department will decide their total credits for each program, and it can vary across disciplines.
2. Courses are categorized into 11 baskets, and a student will have the option to choose courses in most baskets and earn *minimum number of credits* required in each basket for the award of his/her degree. For each basket, Engineering departments have the flexibility to identify course(s) which will be a core requirement for their program.
3. In certain disciplines, students may choose a *Specialization* by earning 18 credits of Discipline Elective courses towards a particular area of that discipline (intradisciplinary). In addition to this, brighter students will have the option to receive (a) a *Certificate* by earning *additional 9* credits towards a particular area either inside or outside their discipline, or (b) *Minor* by earning additional 18 credits towards a particular area outside their discipline. Certificates and Minors can be earned through either University courses, or with MOOCs from providers as identified by the University. Each department will design the structures and eligibility conditions for registration to its certificates or minor program, which may be reviewed annually, to keep the *Certificates* and *Minors* contemporary and relevant to latest changes.
4. An FFCBCS council may be formed comprising all HoDs and one representative each from respective departments. FFCBCS council will meet at the end of every semester after the completion of Board of Examination meeting to discuss and finalize course offerings by

Course Structure & Syllabus of B.Tech.– Petroleum Engineering

Applicable for Batch: 2021-25

respective departments in the upcoming semester. FFCBCS council will be chaired by the Dean Academic Affairs.

5. To provide sufficient flexibility and room during the program for additional *Certificates, Specializations, and Minors*, 8-week summer semesters (Summer 1, Summer 2, and Summer 3) may have to run. Summer semesters are critical for implementing a fully flexible system. Each department will decide *a priori* which courses to offer in the summer semester and get them finalized at the FFCBCS council meeting.
6. Project based learning has to be incorporated as a core component of evaluation in each course, and depending on the level and type of the course, the project can be of several types - Study Oriented Project, Lab Oriented Project, Design Oriented Project, Computer Oriented Project, Projects of Organizational Aspects, Research Projects, or Entrepreneurship and Start Up Projects. A Capstone Project has been introduced in the 8th semester for all Bachelor of Technology students.
7. Courses under each basket may be updated on an annual basis.
8. Each student will be advised by a faculty advisor of his/her department for registration of courses from each basket in the beginning of semester, depending upon the availability of seats. A student advising centre may be formed where students will have access to department faculty advisers. Faculty advisers should have complete access to view individual student's academic transcript for advising purposes.
9. A student getting an F grade in a core course (departmental or otherwise) at the end of the semester will have to earn those credits by registering for the same course whenever it is offered in subsequent semesters. If the course is not a core course, the student may choose to register for any other course next semester in that basket as advised by the department faculty adviser. Additional fees for those number of credits may apply.
10. Students may opt for summer training/internships/industrial tours as advised by the department. However, these activities will not have credits.

Baskets of FFCBCS

11 baskets of courses have been identified to provide student comprehensive exposure to a large number of areas, leading to the holistic development of an individual. These baskets are as follows:

1. **Language and Literature:** These include courses related to English or other popular languages worldwide, communication skills, and literature. These courses are of 3 credits each.
2. **Core Science:** These courses include science courses from the disciplines of Physics and Chemistry. These courses are of 5 credits each.
3. **Core Mathematics:** This basket includes courses from Mathematics department, crafted for Engineering students. These courses are of 4 credits each.
4. **Engineering Sciences:** This basket includes introductory courses from various disciplines of Engineering designed to provide the student solid foundation to the domain of engineering. These courses are of 4 credits each.
5. **Discipline Core:** This basket includes compulsory courses in the discipline in which the student is admitted to the University. These courses are of 4 credits each.
6. **Discipline Elective:** This basket provides students courses other than discipline core, and are normally in certain specialized areas. These courses are of 3 credits each.
7. **Humanities and Liberal Arts:** This basket includes liberal arts courses in various disciplines like psychology, management, economics, etc., and are of 3 credits each.

Course Structure & Syllabus of B.Tech.– Petroleum Engineering

Applicable for Batch: 2021-25

8. **Skill Enhancement:** Courses in this basket are primarily hands-on and aims to allow students acquire skills required in certain disciplines that are currently in high demand in the job market. These courses are of 2 credits each.
9. **Ability Enhancement:** These courses aim to enhance knowledge and ability of an individual in certain required areas related to national and societal interest. Courses in this basket are of 2 credits each.
10. **Free Electives:** Student can register for any three courses outside their department of his/her choice. These courses can also be taken from MOOCs, and a minimum of 9 credits have to be taken by a student in this basket. These courses are of 3 credits each.
11. **Capstone Project:** Capstone project is a semester long multifaceted experimental/research assignment that serves as a culminating academic and intellectual experience for students, taken in the last semester of study. It is of 12 credits and may be done groups of not more than three students, and in three modes as follows:
 - **Mode A:** Project with a department faculty.
 - **Mode B:** Project as part of Industry Internship arranged only by the career and placement service of the University. Students securing this assignment on their own will not be allowed, unless the project is secured at a well-known industry, and duly approved by the department. The department's decision in all such cases will be final.
 - **Mode C:** Semester long project in an academic institute/lab of National/International Importance, secured by students on their own. The department's decision to allow in all such cases will be final.

A separate rule booklet will be released for implementation of Capstone Project.

Structure of the Undergraduate program in Petroleum Engineering

Basket/Area	Min Credits To be taken	Credit per course	Courses
Language and Literature (LL) Core: Professional Communication Elective: Choose any 1 more LL course	6	3	2
Core Sciences (CoS) Core: None Elective: Choose any 2 CoScourse	10	5	2
Core Mathematics (CM) Core: Maths I, Maths II, and Probability & Statistics Elective: None	12	4	3
Engineering Sciences (ES) Core: Fluid Mechanics, Programming for Problem Solving Elective: Choose any 3 more ES courses	20	4	5
Discipline Core (DC) Core: G&G, DT, CT, HMT, FE, PPO-I, PPO-II, RE, OGWT, HSE in PI, EOR, RS Elective: None	48	4	12

Course Structure & Syllabus of B.Tech.– Petroleum Engineering Applicable for Batch: 2021-25

Discipline Elective (DE) Core: None Elective: Choose any 6 courses as per your Specialization	18	3	6
Humanities and Social Sciences (HSS) Core: None Elective: Choose any 3 more HSS Courses	9	3	3
Skill Enhancement Courses (SEC) Core: None Elective: Choose any 4 SEC Courses	8	2	4
Ability Enhancement Courses (AEC) Core: Environmental Science, Indian Constitution, Entrepreneurship and Startups, Aptitude and Softskills Elective: None	8	2	4
Free Electives (FE) Core: None Elective: Choose any 3 courses across University courseofferings	9	3	3
Thesis Project (TP) Mode A: Project with a department faculty Mode B: Project as part of Industry Internship Mode C: Project in an academic institute/lab of NationalImportance. All Modes must be semester long	12	12	1
Total Credits	160		45

Course Structure & Syllabus of B.Tech.– Petroleum Engineering

Applicable for Batch: 2021-25

Course Baskets: For each basket, concerned departments will develop and offer/append courses. A list as discussed in the committee meetings is mentioned below:

Course Code	FFCBCS Baskets (other than DC/DE)				
	Language and Literature (Minimum 6 credits to be taken)	Credits			
	Name of Courses	L	T	P	C
LAF181	Professional Communication*	2	0	2	3
LAF182	Indian English Literature	3	0	0	3
LAF183	English Language Teaching	3	0	0	3
LAF184	Corporate Communication and Soft Skills	2	0	2	3
	Core Science (Minimum 10 credits to be taken)				
	Name of Courses	L	T	P	C
CHF101	Engineering Chemistry (For CS/IT/EE/ECE)	3	1	2	5
CHF102	Applied Engineering Chemistry (for ME/CE/PE)	3	1	2	5
PYF101	Wave & Optics and Introduction to Quantum Mechanics	3	1	2	5
PYF102	Introduction to Mechanics	3	1	2	5
PYF103	Electricity & Magnetism	3	1	2	5
	Core Mathematics (Minimum 12 credits to be taken)				
	Name of Courses	L	T	P	C
MAF101	Engineering Mathematics I *	3	1	0	4
MAF102	Engineering Mathematics II*	3	1	0	4
MAF201	Engineering Mathematics III (EE, ME, CE)	3	1	0	4
MAF202	Probability and Statistics (CSE, IT, ECE, PE) *	3	1	0	4
	Engineering Sciences (Minimum 20 credits to be taken)				
	Name of Courses	L	T	P	C
ECF101	Fundamental of Electronics Engineering.	3	0	2	4
EEF101	Basic Electrical Engineering	3	0	2	4
EEF143	Electrical and Electronics Engineering Practice (non EE/EECE)	3	0	2	4
MEF101	Thermodynamics	3	1	0	4
CSF101	Programming for Problem Solving*	3	0	2	4
CSF102	Data Structures*	3	0	2	4
MEF102	Engineering Graphics	2	0	4	4
MEF103	Engineering Mechanics	2	1	2	4
MEF201	Engineering Materials	3	0	2	4
PEF204	Fluid Mechanics*	3	0	2	4
EEF141	Electrical Engineering Material	3	0	2	4
ECF142	Fundamental of Semiconductor Electronics	3	1	0	4
CEF101	Civil Engineering Materials	3	0	2	4

Course Structure & Syllabus of B.Tech.– Petroleum Engineering

Applicable for Batch: 2021-25

Skill Enhancement (Minimum 8 credits to be taken)					
	Name of Courses	L	T	P	C
PEF XXX	Technical Training 1	1	0	2	2
PEF XXX	Technical Training 2	1	0	2	2
PEF XXX	Value Added Training 1	1	0	2	2
PEF XXX	Value Added Training 2	1	0	2	2
SWAYXX X	MOOCS Courses (as advised by the departments)	2	0	0	2
Ability Enhancement (Minimum 8 credits to be taken)					
	Name of Courses	L	T	P	C
CHF201	Environmental Science*	2	0	0	2
LAF285	Indian Constitution*	2	0	0	2
MEF483	Entrepreneurship and Start-ups*	0	0	4	2
UCF201	Aptitude and Soft Skills*	2	0	0	2
Humanities and Liberal Arts (Minimum 9 credits to be taken)					
	Name of Courses	L	T	P	C
LAF281	Introduction to Psychology	3	0	0	3
LAF282	Human Values	3	0	0	3
LAF283	Literature, Language & Society	3	0	0	3
LAF284	Principles of Management	3	0	0	3
LAF285	Indian Constitution	2	0	0	2
LAF286	Youth Psychology	3	0	0	3
LAF287	Sustainable Development	3	0	0	3
LAF381	Positive Psychology & Living	3	0	0	3
LAF382	Engineering Economics	3	0	0	3
LAF383	Introduction to Linguistics	2	0	2	3
LAF384	Creative Writing	3	0	0	3
LAF385	Health Psychology	3	0	0	3
LAF386	Ecology and Human Development	3	0	0	3
LAF481	Application of Psychology	3	0	0	3
LAF482	Intellectual Property Rights	3	0	0	3
LAF483	Science Technology and Society	3	0	0	3
LAF484	Education and Social Change	3	0	0	3
LAF485	Industrial Psychology	3	0	0	3
LAF486	Innovation and Entrepreneurship	3	0	0	3
Free Electives (Minimum 9 credits to be taken)					
	Name of Courses	L	T	P	C
ECF481	Analogue Electronics (ECE)	2	0	2	3
ECF482	Cellular Communication Network (ECE)	2	0	2	3
ECF381	Microcontroller (ECE)	2	0	2	3
ECF382	Bio Medical Instrumentation (ECE)	2	0	2	3

Course Structure & Syllabus of B.Tech.– Petroleum Engineering

Applicable for Batch: 2021-25

ECF483	Digital Image processing (ECE)	2	0	2	3
CSF381	Software Project Management	3	0	0	3
CSF345	Introduction to Data Science	3	0	0	3
CSF482	Introduction to Cybersecurity	3	0	0	3
MEF381	Composites materials	3	0	0	3
MEF481	Total Quality Management	3	0	0	3
MEF482	Renewable Energy Sources	3	0	0	3
PEF381	Carbon Capture and Sequestration	3	0	0	3
PEF491	Polymer Technology	3	0	0	3
PEF492	Health, Safety and Environment in Industry	3	0	0	3
CEF281	Properties of Materials	3	0	0	3
CEF382	Disaster Preparedness Planning & Management	3	0	0	3
CEF481	Environmental Management & Sustainability	3	0	0	3
CEF482	Natural Dynamics	3	0	0	3
CEF483	GIS	3	0	0	3
CEF484	Resource Dynamics and Economic Implications	3	0	0	3
	Projects (12 Credits)				
UCF439	Capstone Project	0	0	1	1
				2	2

Skill Enhancement Basket

	Name of Courses	L	T	P	C
PEF215	Python for Oil and Gas	1	0	2	2
PEF305	Petroleum Data Analytics	1	0	2	2
PEF315	Machine Learning in Petroleum Operations	1	0	2	2
PEF316	Applied Deep Learning for Predictive Modeling of Petroleum Reservoirs	1	0	2	2

Course Code	FFCBCS Baskets (DC and DE)					
	Discipline Core (Minimum 48 credits to be taken)		Credits			
	Name of Courses	Pre – requisite Courses	L	T	P	C
PEF201	Geology and Geophysical Methods	None	3	0	2	4
PEF202	Chemical Thermodynamics	None	3	1	0	4
PEF203	Drilling Technology	None	3	1	0	4
PEF211	Heat & Mass Transfer Process	PEF202	3	0	2	4
PEF212	Formation Evaluation	PEF201	3	1	0	4
PEF214	Petroleum Production Operations-I	None	3	1	0	4
PEF216	Reservoir Engineering	PEF201	3	0	2	4
PEF302	Petroleum Production Operation-II	PEF214	3	1	0	4
PEF303	Health, Safety and Environment in Petroleum Industry	PEF203	3	1	0	4

Course Structure & Syllabus of B.Tech.– Petroleum Engineering Applicable for Batch: 2021-25

PEF304	Enhanced oil Recovery	PEF216	3	0	2	4
PEF312	Oil and Gas Well Testing	PEF216	3	0	2	4
PEF313	Reservoir Simulation	PEF216	3	0	2	4
	Departmental Electives (Minimum 18 credits to be taken)					
	Name of Courses		L	T	P	C
PEF341	Petroleum Refining and Petrochemicals		2	0	2	3
PEF342	Petroleum Field Instrumentation and Control		2	0	2	3
PEF343	Numerical Methods		3	0	0	3
PEF361	Natural Gas Engineering		3	0	0	3
PEF362	Petroleum Engineering System Design		3	0	0	3
PEF363	Applied Petroleum Reservoir Engineering		3	0	0	3
PEF441	Directional Drilling		3	0	0	3
PEF442	Unconventional Hydrocarbon Resources		3	0	0	3
PEF443	Offshore Drilling and Production Practices		3	0	0	3
PEF444	Petroleum Exploration Methods		3	0	0	3
PEF445	Oil and Gas Field Development		3	0	0	3
PEF446	Oil and Gas Transportation System		3	0	0	3
PEF447	IoT and Cloud Computing in Petroleum Industry		2	0	2	3
PEF448	Cyber Security in Petroleum Industry		3	0	0	3

Course Structure & Syllabus of B.Tech.– Petroleum Engineering Applicable for Batch: 2021-25

Basket/Area	Courses	DIT Credits	Minimum AICTE Credits
Language and Literature (LL)	2	6	NA
Core Sciences (CoS)	2	10	25
Core Mathematics (CM)	3	12	
Engineering Sciences (ES)	5	20	24
Discipline Core (DC)	12	48	48
Discipline Elective (DE)	6	18	18
Humanities and Liberal Arts (HL)	3	9	12
Skill Enhancement Courses (SEC)	4	8	NA
Ability Enhancement Courses (AEC)	4	8	NA
Free Electives (FE)	3	9	18
Capstone Projects (PRJ)	1	12	15
Total	45	160	160

Comparison of DIT University FFCBCS credits with AICTE credits

Course Structure & Syllabus of B.Tech.– Petroleum Engineering Applicable for Batch: 2021-25

Figure: Flowchart of pre-requisites for the DC courses

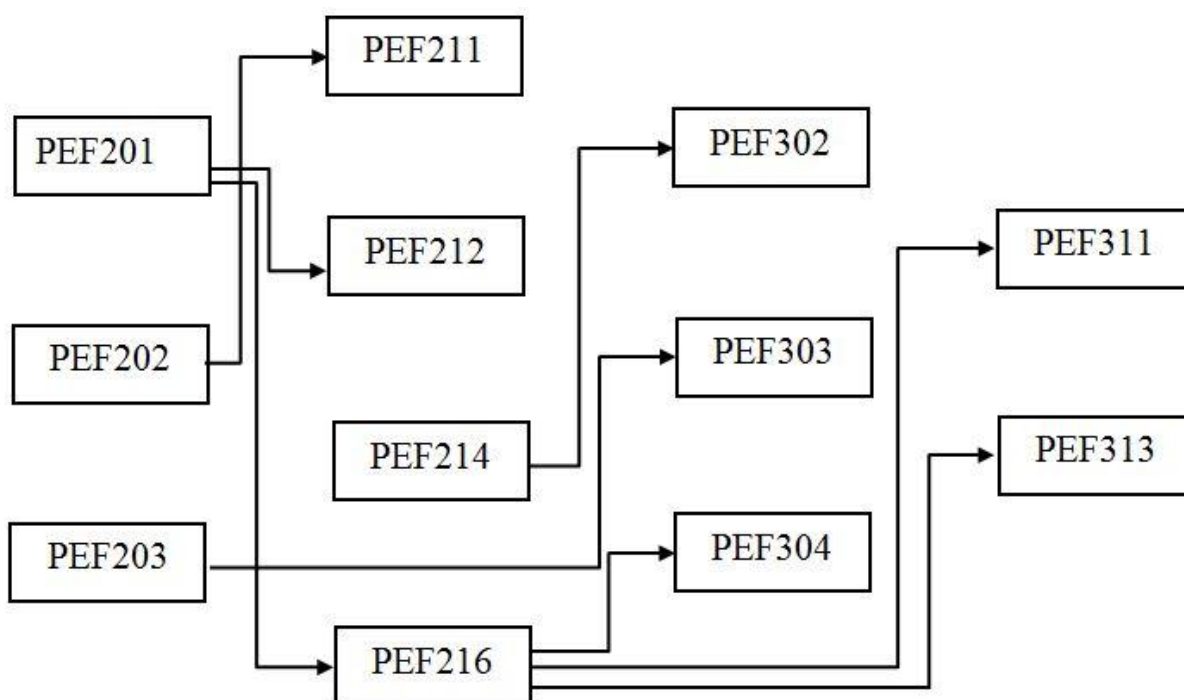

Course Structure & Syllabus of B.Tech.– Petroleum Engineering Applicable for Batch: 2021-25

Flow of Actions for implementing FFCBCS every semester

After release of Final Exam results, FFCBCS council meets to decide & finalize course offerings in each basket



Courses are created in ERP and in LMS with required number of seats



Registrar announces the date for Registration



Students get advised and registers for courses in the Student Advising Centre



List of students gets added in LMS



Class Starts

Course Structure & Syllabus of B.Tech.– Petroleum Engineering

Applicable for Batch: 2021-25

1. Department offering the course	Humanities & Liberal Arts
2. Course Code	LAF181
3. Course Title	Professional Communication
4. Credits (L:T:P:C)	2:0:2:3
5. Contact Hours (L:T:P)	2:0:2
6. Prerequisites (if any)	NIL
7. Course Basket	Language and Literature

8. Course Summary

This course is to enhance the Communication Skills of the students. It also focuses on Basic facets of communication. It introduces the students to LSRW and Non-verbal Language and how to master these aspects to be an effective communicator.

9. Course Objectives

The course aims at developing the LSRW skills of students for effective communication. Also to equip them for a business environment. It also focusses at preparing the students understand and present themselves effectively.

10. Course Outcomes

On successful completion of the course, students will be able to achieve the following:

1. Communicate smoothly
2. Greater self-confidence and knowledge of life skills helps them to develop healthier interpersonal relationships.
3. Present themselves effectively
4. Prepares the students to face future challenges and excel in their personal and professional lives.

11. Curriculum Content

Unit 1: Communication

Communication: Meaning, Types of Communication: General & Technical Communication Knowledge and adoption of Non Verbal cues of communication: Kinesics, Proxemics, Chronemics, Oculistics, Haptics, Paralinguistics, Barriers to Communication, Overcoming strategies.

Unit 2: Listening & Speaking Skills

Listening Comprehension: identifying General & Specific information, Note taking and drawing inferences

Introduction to Phonetics: Articulation of consonants and vowel sounds.

Unit 3: Reading Skills & Technical Writing Skills

Course Structure & Syllabus of B.Tech.– Petroleum Engineering

Applicable for Batch: 2021-25

Reading Strategies and Vocabulary Building Reading Comprehension, Paragraph development, Intra office Correspondence: Notice, Agenda, Minutes and Memorandum Technical Proposal & Report

Unit 4: Communication at Work

Business Letter Writing, Job Application Letter & Resume, Interview Skills, Impression Management, SWOT Analysis (Identifying Strength & Weakness), EQ and Its Dimensions

Textbook(s)

1. Rizvi, Ashraf. Effective Technical Communication, McGraw Hill, New Delhi. 2005.
2. Raman, Meenakshi and Sangeeta Sharma., Technical Communication: Principles and Practice, 2nd Edition. New Delhi: Oxford University Press. 2011.

Reference Books

1. Aslam, Mohammad. Introduction to English Phonetics and Phonology Cambridge.2003.
2. Ford A, Ruther. Basic Communication Skills; Pearson Education, New Delhi.2013.
3. Gupta, Ruby. Basic Technical Communication, Cambridge University Press, New Delhi.2012.
4. Kameswari, Y. Successful Career Soft Skills and Business English, BS Publications, Hyderabad.2010.
5. Tyagi, Kavita& Padma Misra. Basic Technical Communication, PHI, New Delhi. 2011.
6. Ghosh, B. N. Managing Soft skills for Personality development,Laxmi Publications Ltd., New Delhi, 2013.
7. Elizabeth B. Hurlock. Personality Development , TMH Publication,2010

12. Teaching and Learning Strategy

All materials (ppts, assignments, labs, etc.) will be uploaded in Moodle. Assignments, Class Tests etc. will be done. Various teaching methods like Discussion Method, Case Study Method and Lecture Method will be adopted.

Course Structure & Syllabus of B.Tech.– Petroleum Engineering

Applicable for Batch: 2021-25

1. Department offering the course	Humanities & Liberal Arts
2. Course Code	LAF182
3. Course Title	Indian English Literature
4. Credits (L:T:P:C)	3:0:0:3
5. Contact Hours (L:T:P)	3:0:0
6. Prerequisites (if any)	NIL
7. Course Basket	Language and Literature

1. Course Summary

- Indian English Literature is an honest enterprise to demonstrate the ever rare gems of Indian Writing in English. From being a singular and exceptional, rather gradual native flare – up of geniuses, Indian Writing has turned out to be a new form of Indian culture and voice in which India converses regularly. This course will introduce various authors and will help to understand the role of literature in reflecting the social context and the shaping of a young nation.

2. Course Objectives

The course will enable the students to understand the level of Indian English Literature.

- It will also enable the students to understand different genres such as prose, poetry, and fiction in Indian Writers in English.

3. Course Outcomes

On successful completion of the course, students will be able to achieve the following:

Course Outcome:

- The students will develop an insight into Indian literature.
- The students will learn to appreciate different genres of literature of Indian Literature in English.
- The students will understand the role of literature in reflecting the social context and the shaping of a young nation.
- The students will demonstrate knowledge and comprehension of major texts and traditions of language and literature written in English as well as their social, cultural, theoretical, and historical contexts.

4. Curriculum Content

Unit 1

Prose

APJ Abdul Kalam: Unity of Minds

Swami Vivekananda: The Cosmos-Macrocosm

Mahatma Gandhi: Hind Swaraj, What is Civilization? (Chapter XIII) Education (Chapter XVIII)

Unit II

Poetry

Toru Dutt: Our Casuarina Tree

Rabindranath Tagore: Geetanjali – Where the mind is without fear

Course Structure & Syllabus of B.Tech.– Petroleum Engineering

Applicable for Batch: 2021-25

Sri Arbindo:	Stone Goddess
Sarojani Naidu:	Life
Nissim Ezekiel:	The Night of Scorpion
Kamla Das:	An Introduction

Unit III

Short Stories

R.N.Tagore:	Kabuliwala
Mulk Raj Anand:	Duty
R.K. Narayan:	An Astrologer's Day
NayantaraSehgal:	Martand

Unit IV

Novel

Ruskin Bond: Flights of Pigeons

Textbook(s).

1. Kumar, Shiv K. (ed), Contemporary Indian Short Stories in English, 2007 SahityaAkademi.
2. Anand, Mulk Raj; SarosCowasjee (ed.); Selected Short Stories Penguin Books, 2006
3. Bond, Ruskin. Flights of Pigeons, Penguin Books, 2003

Reference Books

1. Tagore, Rabindra. Nationalism. Delhi: Rupa Publications, 1992.Print.
2. Chinhade, Sirish. Five Indian English Poets. New Delhi: Atlantic Publishers and Distributors, 1996.Print.
3. Naik, M.K. A History of Indian English Literature. New Delhi: SahityaAkademi, 2004.Print.
4. Agrawal, K.A. Ed. Indian Writing In English: A Critical Study. Atlantic Publishers &Dist, 2003.Print.

5. Teaching and Learning Strategy

All materials (ppts, assignments, labs, etc.) will be uploaded in Moodle. Refer to your course in Moodle for details.

Course Structure & Syllabus of B.Tech.– Petroleum Engineering

Applicable for Batch: 2021-25

1. Department offering the course	Humanities & Liberal Arts
2. Course Code	LAF183
3. Course Title	English Language Teaching (ELT)
4. Credits (L:T:P:C)	3:0:0:3
5. Contact Hours (L:T:P)	3:0:0
6. Prerequisites (if any)	NIL
7. Course Basket	Language and Literature

8. Course Summary

This course will offer a historical perspective to the teaching of English as a second language. It will trace the changes in language teaching methods throughout history depending on changes in the kind of proficiency learners need. It includes the different approaches used over the years and their application in teaching English as a second language in the classroom. It also traces the status of English language and the 'World English' and how it affects the teaching of English.

9. Course Objectives

To introduce students to the nature of English language learning and its theoretical implications. The main objective of the course is to enable students to evaluate a variety of language learning methods and approaches. It also aims to empower students to understand ELT in their contexts of language learning.

10. Course Outcomes

On successful completion of the course, students will be able to achieve the following:

1. Students will learn about communicative approaches to English language teaching.
2. Be able to understand the theories and methodologies of ELT
3. Be able to explore core components of communicative language teaching
4. Students will learn to apply ELT theories

11. Curriculum Content

Unit 1

Historical Perspective , ELT and its beginnings: development of reading approach, oral method and audio-lingual method

Unit 2

Communicative Language Teaching (CLT): the concept of 'communicative competence; ESL in India: a historical trajectory

Unit 3

Halliday's notion of 'transitivity' and 'meta-functions'

Corpus Linguistics ELT: corpus studies and how it can be used for language teaching

Course Structure & Syllabus of B.Tech.– Petroleum Engineering

Applicable for Batch: 2021-25

Unit 4

‘World English’ and ELT, Model of the ‘Concentric Circles’ and its impact on ELT

Textbook(s)

1. Maybin, Janet and Swann, Joan. (2009). The Routledge Companion to English Language Studies. London: Routledge, Print

Reference Books

1. Richards, J. & T.S. Rogers. (1986). Approaches and Methods in Language Teaching. Cambridge: Cambridge University Press, Print.
2. Ur, Penny. (1996). A Course in Language Teaching: Practice and Theory. Cambridge: Cambridge University Press, Print.

12. Teaching and Learning Strategy

All materials (ppts, assignments, labs, etc.) will be uploaded in Moodle. Refer to your course in Moodle for details.

Course Structure & Syllabus of B.Tech.– Petroleum Engineering

Applicable for Batch: 2021-25

1. Department offering the course	Physics
2. Course Code	PYF101
3. Course Title	Wave & Optics and Introduction to Quantum Mechanics
4. Credits (L:T:P:C)	3:1:2:5
5. Contact Hours (L:T:P)	3:1:2
6. Prerequisites (if any)	NIL
7. Course Basket	Core Sciences

1. Course Summary

2. Course Objectives

The objective of this course is to develop a fundamental basis of waves, optical phenomenon, concepts of quantum mechanics and semiconductor physics which the engineering students can apply to their respective area of specialization.

3. Course Outcomes

On successful completion of the course, students will be able to achieve the following:

1. To acquire skills allowing the student to identify and apply formulas of optics and wave physics using course literature.
2. To be able to identify and illustrate physical concepts and terminology used in optics and to be able to explain them in appropriate detail.
3. To be able to make approximate judgments about optical and other wave phenomena when necessary.
4. To acquire skills allowing the student to organize and plan simpler laboratory course experiments and to prepare an associated oral and written report.
5. To have basic knowledge of Quantum Mechanics and Semiconductors.

Unit 1:

Mechanical and electrical simple harmonic oscillators (characteristics and energy), damped harmonic oscillator, forced mechanical and electrical oscillators, impedance.

Unit 2:

Transverse wave on a string, the wave equation on a string, harmonic waves, reflection and transmission of waves at a boundary, standing waves and their eigen frequencies, longitudinal waves and the wave equation for them, acoustics waves (Newton formula and Laplace correction).

Unit 3:

Huygens' principle, superposition of waves and interference of light by wave front splitting and amplitude splitting; Young's double slit experiment, fringes with white light, interference in parallel thin films, Newton's rings, Fraunhofer diffraction from a single slit & N- slits, Rayleigh criterion for limit of resolution and its application to vision; Diffraction gratings and their resolving power.

Unit 4:

Einstein's theory of matter radiation interaction and A and B coefficients; amplification of light by population inversion, components of LASER and pumping methods (in brief), different types of lasers: gas lasers (He-Ne), solid-state laser (ruby)

Unit 5:

Wave nature of particles, Phase velocity, wave-packet and group velocity, Uncertainty principle and its applications, time-dependent and time-independent Schrodinger equation, physical significance of wave

Course Structure & Syllabus of B.Tech.– Petroleum Engineering

Applicable for Batch: 2021-25

function., Solution of stationary-state Schrodinger equation for one dimensional problem–particle in a box, potential barrier.

Textbook(s)

1. N. K Bajaj, Physics of Waves and Oscillations, Tata McGraw-Hill, 2008
2. Ajoy Ghatak, Optics, McGraw Hill Education, 2017.
3. D. J. Griffiths, Quantum mechanics, Pearson Education, 2015.

Reference Books

1. H. J. Pain, The physics of vibrations and waves, Wiley, 2008
2. E. Hecht, Optics, Pearson Education, 2008

SR.NO. LIST OF EXPERIMENTS

- | | |
|----|--|
| 1 | (a) To determine wavelength of sodium light using Newton's Rings.
(b) To determine the refractive index of a liquid using Newton's Rings. |
| 2 | To determine wavelength of sodium light using Fresnel's Biprism. |
| 3 | (a) To determine wavelength of prominent lines of mercury using plane diffraction grating.
(b) To determine the dispersive power of a plane transmission diffraction grating. |
| 4 | To determine the specific rotation of cane sugar solution using bi-quartz polarimeter |
| 5 | To study the diffraction pattern of Single slit and hence determine the slit width. |
| 6 | (a) To verify cosine square law (Malus Law) for plane polarized light.
(b) To study the nature of polarization using a quarter wave plate. |
| 7 | To study the variation of refractive index of the material of the prism with wavelength and to verify Cauchy's dispersion formula |
| 8 | (a) To study photoelectric effect and determine the value of Planck's constant.
(b) To verify inverse square law using photocell. |
| 9 | To determine the frequency of AC mains using sonometer. |
| 10 | To determine the frequency of AC mains or of an electric vibrator by Melde's experiment |
| 11 | To measure the numerical aperture (NA) of an optical fiber. |

4. Teaching and Learning Strategy

All materials (ppts, assignments, labs, etc.) will be uploaded in Moodle. Assignments, Class Tests etc. will be done. Various teaching methods like Discussion Method, and Lecture Method will be adopted.

Course Structure & Syllabus of B.Tech.– Petroleum Engineering

Applicable for Batch: 2021-25

1. Department offering the course	Physics
2. Course Code	PYF102
3. Course Title	Introduction to Mechanics
4. Credits (L:T:P:C)	3:1:2:5
5. Contact Hours (L:T:P)	3:1:2
6. Prerequisites (if any)	NIL
7. Course Basket	Core Sciences

8. Course Objectives

Mechanics lies at the foundation of physics and along with an appreciation of the molecular structure of matter exposes the student to the phenomenology of physics.

9. Course Outcomes

On successful completion of the course, students will be able to achieve the following:

1. To know Newton's laws of motion, potentials, conservation of energy, momentum and angular momentum, and be able to apply them to projectiles, circular motion, and gravity
2. Demonstrate an understanding of intermediate mechanics topics such as co-ordinate transformations, oscillatory motion, gravitation etc.
3. Demonstrate rigid body and rotational dynamics using the concept of angular velocity and momentum.
4. Understand the concept of non-inertial frames of reference, coriolis and centripetal accelerations and their applications.
5. Understand the concept of elastic constants and demonstrate bending of beams.

10. Curriculum Content

Unit 1:

Transformation of scalars and vectors under Rotation transformation; Newton's laws and its completeness in describing particle motion, Cylindrical and spherical coordinates Mechanics of a system of particles, conservation of laws of linear momentum, angular momentum and mechanical energy, centre of mass and equation of motion, Constraints and degrees of freedom.

Unit 2:

Potential energy function; $F = -\text{Grad } V$, Equipotential surfaces and meaning of gradient; Conservative and non-conservative forces, curl of a force field; Central forces; Conservation of Angular Momentum and areal velocity; Elliptical, parabolic and hyperbolic orbits

Unit 3:

Non-inertial frames of reference; Rotating frames of reference, Coriolis force; Applications: Weather systems, projectile motion

Unit 4:

Harmonic oscillator; Damped harmonic motion – over-damped, critically damped and lightly-damped

Course Structure & Syllabus of B.Tech.– Petroleum Engineering

Applicable for Batch: 2021-25

oscillators; Forced oscillations and resonance, Kater's Pendulum and bar pendulum.

Unit 5:

Rotation of rigid body, Moment of Inertia, Torque, angular momentum, kinetic energy of rotation, Theorems of perpendicular and parallel axis, Moment of Inertia of rectangular rod, spherical and cylindrical bodies. Acceleration of a body moving on horizontal and inclined plane. Moment of inertia of Fly Wheel.

Unit 6:

Elastic constants- Introduction and relationship between elastic constants, Cantilever, Beam, Bending of beam, Twisting of a cylindrical body.

Textbook(s)

1. Mechanics – D.S. Mathur, S. Chand & Co., 2012.
2. Introduction to Mechanics –D.Kleppner&R.Kolenkow, Cambridge University Press, 2017

Reference Books

1. Analytical Mechanics, G.R. Fowles and G.L. Cassiday., Cengage Learning India Pvt. Ltd., 2006
2. Introduction to Special Relativity, R. Resnick, John Wiley and Sons, 2007
3. Principles of Mechanics — J.L. Synge & B.A. Griffiths, Andesite Press, 2015

SR.NO.	LIST OF EXPERIMENTS
1	To measure internal diameter, external diameter and depth of a vessel using vernier calipers
2	To measure density of a wire using screw gauge.
3	To determine the Moment of Inertia of a Flywheel
4	To determine Coefficient of Viscosity of water by Capillary Flow Method (Poiseuille's method)
5	To determine the Modulus of Rigidity of a Wire by Maxwell's needle
6	To determine the elastic Constants of a wire by Searle's method
7	To determine the value of g using Bar Pendulum
8	To measure the Young's Modulus using Bending of Beam
9	To determine the value of g using Kater's Pendulum
10	To determine the moment of inertia of a body using Torsion pendulum

11. Teaching and Learning Strategy

All materials (ppts, assignments, labs, etc.) will be uploaded in Moodle. Assignments, Class Tests etc. will be done. Various teaching methods like Discussion Method, and Lecture Method will be adopted.

Course Structure & Syllabus of B.Tech.– Petroleum Engineering

Applicable for Batch: 2021-25

Subject Code	PYF103
Marks	100
Number of Lecture Hours/Week	3
Total Number of Contact Hours	6x13=78
CREDITS	5 (L T P : 3 1 2)
COURSE OBJECTIVE: To teach students the effects of electric charges at rest and in motion. Both positive and negative charges produce force field which is called “electric field”. Moving charges produce current, which gives rise to another force field called “magnetic field”. The electromagnetic theory studies the behavior of the electric and magnetic fields.	
COURSE OUTCOME: Having successfully completed this course, the student will be able to demonstrate knowledge and understanding of: CO1. The use of Coulomb's law and Gauss' law for the electrostatic force CO2. The relationship between electrostatic field and electrostatic potential CO3. The use of the Lorentz force law for the magnetic force CO4. The use of Ampere's law to calculate magnetic fields CO5. The use of Faraday's law in induction problems CO6. The basic laws that underlie the properties of electric circuit elements	
Particulars	Hours
Unit 1: Electrostatics in vacuum	
Calculation of electric field and electrostatic potential for a charge distribution; Divergence and curl of electrostatic field; Gauss law and its applications, Laplace’s and Poisson’s equations; Practical examples like Faraday’s cage and coffee-ring effect; energy of a charge distribution and its expression in terms of electric field.	9
Unit 2: Electrostatics in a linear dielectric medium	
Electrostatic field and potential of a dipole. Bound charges due to electric polarization; Electric displacement; gauss law in dielectrics; Polarization vector, solving simple electrostatics problems in presence of dielectrics – Point charge at the centre of a dielectric sphere, charge in front of a dielectric slab, dielectric slab and dielectric sphere in uniform electric field. Energy in dielectrics system	7
Unit 3: Magnetostatics	
Electric current and current density, magnetic force, continuity equation, Bio-Savart law and its applications(straight wire and solenoid), Divergence and curl of static magnetic field; Ampere circuital law and its applications(wire, solenoid & toroid), current loop as magnetic dipole and dipole moment, Para, dia and ferro magnetic materials (properties only)	9
Unit-4: Faraday’s law	
Faraday’s law in terms of EMF produced by changing magnetic flux; equivalence of Faraday’s law and motional EMF; Lenz’s law; Electromagnetic braking and its applications; Differential form of Faraday’s law expressing curl of electric field in terms of time-derivative of magnetic field and calculating electric field due to changing magnetic fields in quasi-static approximation; energy stored in a magnetic field.	6

Course Structure & Syllabus of B.Tech.– Petroleum Engineering

Applicable for Batch: 2021-25

Unit- 5: Displacement current, Magnetic field due to time-dependent electric field and Maxwell's equations	
Concept of displace current, Modifying equation for the curl of magnetic field to satisfy continuity equation; and magnetic field arising from time-dependent electric field; Maxwell's equation in integral and differential form in vacuum and non-conducting medium; transverse nature of EM wave, Wave equation in free space, Wave propagation in conducting medium and non conducting medium & skin depth, Flow of energy and Poynting vector.	9
TEXT BOOKS	
1. David Griffiths, Introduction to Electrodynamics, PHI Learning, 2012.	
REFERENCE BOOKS	
1. Halliday and Resnick, Physics, Wiley, 2013. 2. W. Saslow, Electricity, Magnetism and Light, Academic Press, 2002.	

SR.NO.	LIST OF EXPERIMENTS (ANY TEN)
1	Identification of various electronic components.
2	Use of multimeter for testing diodes, LEDs, transistors and measurements of resistance, capacitance, inductance, dc voltage, dc current, ac voltage, ac current and frequency of ac mains.
3	Charging and discharging of capacitor through resistance and determination of time constant.
4	To determine the specific resistance of a given wire using Carey Foster's bridge.
5	To verify Stefan's law by electrical method.
6	To study the variation of magnetic field with distance along the axis of a current carrying coil and determination of radius of the coil.
7	To calibrate the given voltmeter using potentiometer.
8	To calibrate the given ammeter using potentiometer.
9	To determine the band gap of a semiconductor p-n junction.
10	To determine the resistance of a sample using four probe method.
11	To determine the band gap of semiconductor using four probe method.
12	To determine a unknown resistance using Wheatstone bridge.

Course Structure & Syllabus of B.Tech.– Petroleum Engineering

Applicable for Batch: 2021-25

1. Department offering the course	Department of Chemistry
2. Course Code	CHF101
3. Course Title	Engineering Chemistry
4. Credits (L:T:P:C)	3:1:1:5
5. Contact Hours (L:T:P)	3:1:2
6. Prerequisites (if any)	NIL
7. Course Basket	Core Science Elective

8. **Course Summary:** It covers fundamentals of Chemistry required for the engineering students.

9. **Course Objectives:** The objective of the course is to provide a summery on water treatment, Fuels, green chemistry and synthetic chemistry. The course is specifically designed for CSE& IT students to give them an overview of the working principles, mechanisms, reactions and applications of the building blocks of batteries, cells and surface coatings to protect the metal.

10. Course Outcomes:

At the end of the course student will get:

CO1: To understand about the treatment of water, sewage water and hardness related calculations.

CO2: An overview of of the working principles, mechanism of reactions and applications of cells, electrodes and batteries.

CO3: An overview of different types, mechanism of corrosion its prevention and surface coatings.

CO4: The concept of different types of fuel, lubricants. They will understand about their applications in various industries and also about latest development in the field of alternative fuels.

CO5: aware of how chemical processes can be designed, developed and run in a sustainable way. Students acquire the competence to think of chemistry as a sustainable activity.

11. Curriculum Content:

Unit 1: Water Treatment and Analysis

(08 Lectures)

Standards for drinking water, Water Quality parameters, Determination of alkalinity of water, Hardness of water: Units and determination. Demineralization of water, softening of water: Lime-soda Process, Ion exchange process, Zeolite process and RO process. Internal conditioning methods: Carbonate conditioning, Phosphate conditioning, Colloidal conditioning, Calgon conditioning. Desalination of brackish water

Unit 2: Electrochemistry

(06 Lectures)

Migration of ions, Transference number, Determination of Transference number by Hittorf's method, Conduct metric titrations, Types of electrode: Calomel and glass electrode, Battery.

Unit 3: Corrosion

(06 Lectures)

Corrosion and its economic aspects, Types of corrosion: Galvanic, Erosion, Crevice, Pitting, Waterline, Soil, Microbiological. Theories of corrosion: Acid, Direct Chemical attack, Electrochemical. Corrosion prevention by metallic, organic/inorganic coatings and corrosion inhibitors

Course Structure & Syllabus of B.Tech.– Petroleum Engineering

Applicable for Batch: 2021-25

Unit 4: Fuels, Lubrication

(08 Lectures)

Classification of fuels, Calorific value, Cetane number, Octane number, fuel quality, Comparison of solid, liquid and gaseous fuel, properties of fuel, alternative fuels: Biofuels, Power alcohol, Introduction of Lubricants, Functions of Lubricants, Classification of lubricants, Mechanisms of Lubrication, Properties of Lubricants.

Unit 5: Green Chemistry

(08 Lectures)

Emergence of green chemistry, twelve principle of green chemistry, Use of alternative Feedstock (biofuels), Use of innocuous reagents, use of alternative solvents, design of safer chemicals, designing alternative reaction methodology, minimizing energy consumption

Text Books Recommended:

1. Engineering Chemistry by Shikha Agarwal. Cambridge University Press Edition 2015.
2. Engineering Chemistry by S. Vairam & Suba Ramesh. Wiley India Pvt. Ltd. 2014.

Reference Books:

1. Environmental Chemistry by Stanley E. Manahan. CRC Press Taylor and Francis.
2. Organic Chemistry by Morrison and Boyd. Pearson.
3. Physical Chemistry by Atkins. Oxford University Press.
4. Concise Inorganic Chemistry by J.D. Lee. Oxford University Press.

LIST OF PRACTICALS

1. Determination of alkalinity in the given water sample.
2. Estimation of temporary and permanent hardness in water sample using EDTA as standard solution.
3. Calculation of percentage of available chlorine in bleaching powder.
4. Chloride content in the given water sample by Mohr's method.
5. Determination of iron content in the given ore by using external indicator
6. pH-metric titration.
7. Proximate Analysis of coal sample
8. Flash and Fire point determination of a Lubricant
9. To determine the DO in a given water sample
10. Viscosity of a lubricant by Redwood Viscometer

12. Teaching and Learning Strategy

All materials (ppts, assignments, labs, etc.) will be uploaded in Moodle. Refer to your course in Moodle for details.

Course Structure & Syllabus of B.Tech.– Petroleum Engineering

Applicable for Batch: 2021-25

1. Department offering the course	Department of Chemistry
2. Course Code	CHF102
3. Course Title	Applied Engineering Chemistry
4. Credits (L:T:P:C)	3:1:1:5
5. Contact Hours (L:T:P)	3:1:2
6. Prerequisites (if any)	NIL
7. Course Basket	Core Science Elective

8. **Course Summary:**It covers fundamentals of Chemistry required for the engineering students.

9. **Course Objectives:**The objective of the course is to provide a summary on water treatment, Fuels, green chemistry and synthetic chemistry. The course is specifically designed for non CSE students to give them an overview of the working principles, mechanisms, reactions and applications of the building blocks of batteries, cells and surface coatings to protect the metal.

10. Course Outcomes:

At the end of the course student will get:

CO1: To understand about the treatment of water, sewage water and hardness related calculations.

CO2: An overview of electrical properties of the metals and detailed knowledge of semiconductors.

CO3: The basic fundamental behind selection of engineering materials and their properties required depending on their applications.

CO4: The concept of different types batteries and their applications.

CO5: Aware of how chemical processes can be designed, developed and run in a sustainable way. Students acquire the competence to think of chemistry as a sustainable activity.

11. Curriculum Content:

Unit 1 Water Technology (08 Lectures)

Standards for drinking water, Water Quality parameters, Demineralization of water, softening of water: Lime-soda Process, Ion exchange process, Zeolite process and Reverse Osmosis process. Internal conditioning methods: Carbonate conditioning, Phosphate conditioning, Colloidal conditioning, Calgon conditioning, Desalination of brackish water, sterilization of water.

Unit 2 Conductivity of solids (06 Lectures)

Introduction, Electrical properties of solids, Band theory of solids, Types of energy bands, Application of band theory to solids, Elemental semiconductors, Non-elemental semiconductors, Non-stoichiometric n-type semiconductors, Chalcogen semiconductors

Unit 3 Engineering Materials (10 Lectures)

Introduction of polymers; Classification of Polymers; Functionality; Mechanism of Polymerization; Plastics; Individual Polymers; LDPE, HDPE, PVC, Polystyrene, Bakelite,

Course Structure & Syllabus of B.Tech.– Petroleum Engineering

Applicable for Batch: 2021-25

Teflon, PMMA, PET, Nylon-6, Rubbers (BUNA-S and BUNA-N); Specialty Polymers (Conducting Polymers, Silicones and Polycarbonates), Gypsum, Plaster of Paris, Insulating Materials

Unit 4 Battery Technology (06 Lectures)

Battery, Photovoltaic cell, Metal-air battery, Lithium and nickel battery

Unit 5 Green Chemistry (08 Lectures)

Emergence of green chemistry, Twelve principle of green chemistry, Use of alternative Feedstock (biofuels), Use of innocuous reagents, use of alternative solvents, design of safer chemicals, designing of alternative reaction methodology, minimizing energy consumption.

Text Books Recommended:

1. Engineering Chemistry by Shikha Agarwal. Cambridge University Press Edition 2015.
2. Engineering Chemistry by S. Vairam&Suba Ramesh. Wiley India Pvt. Ltd. 2014.

Reference Books:

1. Environmental Chemistry by Stanley E. Manahan. CRC Press Taylor and Francis.
2. Organic Chemistry by Morrison and Boyd. Pearson.
3. Physical Chemistry by Atkins. Oxford University Press.
4. Concise Inorganic Chemistry by J.D. Lee. Oxford University Press.

LIST OF PRACTICALS

1. Determination of alkalinity in the given water sample.
2. Estimation of temporary and permanent hardness in water sample using EDTA as standard solution.
3. Calculation of percentage of available chlorine in bleaching powder.
4. Chloride content in the given water sample by Mohr's method.
5. Determination of iron content in the given ore by using external indicator
6. pH-metric titration.
7. Proximate Analysis of coal sample
8. Flash and Fire point determination of a Lubricant
9. To determine the DO in a given water sample
10. Viscosity of a lubricant by Redwood Viscometer

12. Teaching and Learning Strategy

All materials (ppts, assignments, labs, etc.) will be uploaded in Moodle. Refer to your course in Moodle for details.

Course Structure & Syllabus of B.Tech.– Petroleum Engineering

Applicable for Batch: 2021-25

1. Department offering the course	Mathematics
2. Course Code	MAF101
3. Course Title	ENGINEERING MATHMATICS-I
4. Credits (L:T:P:C)	3:1:0:4
5. Contact Hours (L:T:P)	3:1
6. Prerequisites (if any)	NIL
7. Course Basket	Core Sciences

OBJECTIVE: To introduce the fundamentals in Differential, Integral and Vector Calculus relevant to engineering applications.

Unit I

Review of Limit, Continuity and differentiation, Successive Differentiation, Leibnitz theorem

(without proof), Problems based on Leibnitz's theorem, Maclaurin's series in one variable, Taylor's expansion in one variable, Asymptote & Curvature, Point of inflexion, Double Points, Cusp, Node and conjugate points, Curve tracing for Cartesian curves.

Unit II

Partial differentiation and problems, Euler's theorem and its proof, Problems based on Euler's

theorem, Few corollaries on Euler's theorem for higher order derivatives and problems based on them, Taylor's expansion of a function in two variables, Jacobians, its properties, and transformations of coordinates, Maxima and minima of a function in two variables, Method of Lagrange's multipliers and problems.

Unit III

Double and triple integrals, Change of order of integration, Change of variables, Application of

integration to lengths, Surface, areas and Volumes- Cartesian and Polar coordinates. Beta and Gamma functions, Dirichlet's integral and its applications.

Unit IV

Scalar and Vector fields, Vector differentiation, Directional derivatives Gradient, Divergence

and curl and their physical significance. Evaluation of Line integral, Green's theorem in plane (without proof), Stokes theorem (without proof), Gauss Divergence theorem (without proof) and problems based on them.

LEARNING OUTCOME: Students will be able to:

- Use techniques for determining area under a curve, extrema of functions and their use in drawing graphs.

Course Structure & Syllabus of B.Tech.– Petroleum Engineering

Applicable for Batch: 2021-25

- Compute partial derivatives of functions of two or more variables and use them for determining extrema, saddle points of the surfaces of given functions.
- Use vector calculus in determining motions of fluids, work done by a force etc..
- Theorems like Greens theorem, Diverges theorem, Stocks theorem and their applications in determining surface area and volume.

Text Books:

1. G. B. Thomas Jr. & R. L. Finney, Calculus and Analytic Geometry, 9th Edition, Pearson Education
2. R. K. Jain and S.R.K. Iyenger, Advanced Engineering Mathematics, 2nd edition, Narosa Publishing House, New Delhi, India,2006

Reference Books:

1. E. Kreyszig, Advanced Engineering Mathematics, 9th Edition, John Wiley & Sons, U.K., 2006.

Course Structure & Syllabus of B.Tech.– Petroleum Engineering

Applicable for Batch: 2021-25

1. Department offering the course	Mathematics
2. Course Code	MAF102
3. Course Title	ENGINEERING MATHMATICS-II
4. Credits (L:T:P:C)	3:1:0:4
5. Contact Hours (L:T:P)	3:1
6. Prerequisites (if any)	NIL
7. Course Basket	Core Sciences

OBJECTIVE: To introduce the fundamentals in Matrices and Linear Algebra, Ordinary Differential Equations, Laplace Transform and Infinite Series relevant to engineering applications.

UNIT I

Elementary row operations, row reduced Echelon form, rank of a matrix, invertible matrices,

Consistency of linear system of equations and their solution, Linear independence and dependence of vectors, Vector Spaces and its basis, Linear Transformations, Eigenvalues and Eigenvectors, Cayley-Hamilton Theorem, Diagonalization of matrices.

UNIT II

Order, degree of ODE and some basic concepts such as linearity and nonlinearity, general so-

lution and particular solution, formation of ODEs, First order differential equation: variable separable method, homogeneous method, and its variants, Linear differential equation of second order with constant coefficients: Complementary function and particular integral for some standard functions, Cauchy Euler linear differential equation, Solution of second order linear differential equation with variable coefficients, method of variation of parameters, solution of simultaneous linear differential equations.

UNIT III

Laplace transform of some standard functions, Properties of Laplace transform, Inverse Laplace

transforms, Properties of Inverse Laplace transforms, using partial fractions for inverse Laplace transforms, Convolution theorem (without proof), Application of Laplace transforms to solve various types of differential equation, e.g., differential equations with constant coefficient, variable coefficients, simultaneous differential equations.

UNIT IV

Introduction to sequence and series, series of positive terms, comparison test, D'Alembert's ratio test, Root Test, Alternating series, Leibnitz test. Fourier series of periodic functions, Euler's formulae, functions having arbitrary period, change of intervals, even and odd functions, half range sine and cosine series.

Course Structure & Syllabus of B.Tech.– Petroleum Engineering

Applicable for Batch: 2021-25

Outcome: Students will be able to:

- Differentiate between invertible and singular matrices, determine characteristic equations of a matrix and hence eigen values and eigen vector for a given matrix.
- Determine differential equations satisfied by various physical application and their solutions.
- Use properties of improper integrals to define Laplace Transforms and use them to solve initial value physical problems
- Mathematically deal with infinite series and test their convergence.

Text Books:

- 1.R. K. Jain & S. R. K. Iyenger, Advanced Engineering Mathematics, 2nd Edition, Narosa Publishing House, New Delhi, India, 2006.
- 2.E. Kreyszig, Advanced Engineering Mathematics, 9th Edition, John Wiley & Sons, U.K., 2006.

Reference Books:

- 1.W. E. Boyce and R. Di Prima, Elementary Differential Equations, (8th Edition), John Wiley & Sons, U.K., (2005).
- 2.B. S. Grewal, Higher Engineering Mathematics, 42nd Edition, Khanna Publication, New Delhi, India, 2012

Course Structure & Syllabus of B.Tech.– Petroleum Engineering

Applicable for Batch: 2021-25

1. Department offering the course	Mathematics
2. Course Code	MAF201
3. Course Title	ENGINEERING MATHMATICS-III
4. Credits (L:T:P:C)	3:1:0:4
5. Contact Hours (L:T:P)	3:1
6. Prerequisites (if any)	NIL
7. Course Basket	Core Sciences

OBJECTIVE: Introduce the fundamentals in Complex variable.Solving Partial Differential Equations. Legendre polynomial of first kind with properties.Bessel function of first kind and its properties.

UNIT I

Series solution of ODE of 2nd order with variable coefficient with special emphasis to Legendre and Bessel differential equation by Frobenious method, Legendre polynomial of first kind, Bessel function of first kind and their properties.

UNIT II

Introduction and formation of Partial Differential Equations, Classification of Partial Differential

Equations, Solution of first order linear partial differential equations of the form $Pp + Qq = R$, LinearPDE with constant coefficients of IInd order. Method of separation of variables, Solution of wave equationin one dimension, Solution of heat in one dimension and Laplace equation using method of separation ofvariables.

UNIT III

Concept of Limit, continuity, and differentiability, Analytic functions, C-R equations and har-

monic functions, Line integral in the complex plane, Cauchy's integral theorem, Cauchy's integral formula for derivatives of analytic function. Representation of a function by power series, Taylor's andLaurent's series, R Singularities, zeroes and poles, Residue theorem, evaluation of real integrals of

type $\int_0^{2\pi} f(\cos \theta, \sin \theta) d\theta$ and $\int_{-\infty}^{\infty} f(x) dx$.

UNIT III

Fourier integral; Fourier transform; Fourier sine and cosine transform; linearity, scaling, fre-

quency shifting and time shifting properties; convolution theorem. Z-transform; properties of Z-transforms; Convolution of two sequences; inverse Z-transform. Applications of Fourier Transform and Z-Transform.

Outcome: The student will be able to use

Course Structure & Syllabus of B.Tech.– Petroleum Engineering

Applicable for Batch: 2021-25

- Familiarity with methods to solve partial differential equations.
- Differentiation and Integration of complex functions to physical problems.
- Complex integration for solving real integrals.
- Fourier and Z-transform rules to physical problems.

Text Books:

1. J.W. Brown & R. V. Churchill: Complex Variables & Applications, 9th edition, McGraw-Hill, 2013.
2. R. K. Jain & S. R. K. Iyenger, Advanced Engineering Mathematics, 2nd Edition, Narosa Publishing House, New Delhi, India, 2014.

Reference Books:

1. B. S. Grewal, Higher Engineering Mathematics, 42th Edition, Khanna publication, New Delhi, India, 2012.
2. E. Kreyszig, Advanced Engineering Mathematics, 9th Edition, John Wiley & Sons, U.K., 2006.

Course Structure & Syllabus of B.Tech.– Petroleum Engineering

Applicable for Batch: 2021-25

1. Department offering the course	Mathematics
2. Course Code	MAF202
3. Course Title	Probability and Statistics
4. Credits (L:T:P:C)	3:1:0:4
5. Contact Hours (L:T:P)	3:1
6. Prerequisites (if any)	NIL
7. Course Basket	Core Sciences

OBJECTIVE: The objectives of the course are to familiarize the students with statistical techniques, to equip them with standard concepts and, to learn tools of probability theory to solve engineering problems.

Unit I: Descriptive Statistics and Probability

Review of mean, median and mode, variance. Moments and properties, Skewness and Kurtosis. Probability: concepts, definition, examples, conditional probability and Bayes' theorem.

Unit II: Random Variables and Probability Distributions

Discrete & continuous random variables and their properties, mass function, density function, distribution functions. Expectation, moment generating function, Binomial, Poisson, Exponential & Normal distributions and their applications.

Unit III: Correlation and Regression

Bivariate distributions and their properties, Joint and marginal density functions, Conditional densities. Covariance, Correlation, Regression, Regression lines. Curve fitting by the method of least square-fitting of straight lines.

Unit IV: Hypothesis Testing

Population and samples, Sampling distribution of statistic, standard error. Null and Alternative Hypothesis, critical region, critical values and level of significance. One tail and two-tail tests, confidence interval, Errors in testing of hypothesis; Type I and Type II errors, power of the test.

Unit V: Inferential test procedures

Test of significance, large sample test for single proportion, difference of proportion, single mean, difference of means and difference of standard deviation. Small sample test: Student's t-test and its applications, F-test and its applications. Chi-square test for goodness of fit and independence of attributes.

LEARNING OUTCOME: Students will be able to:

Course Structure & Syllabus of B.Tech.– Petroleum Engineering

Applicable for Batch: 2021-25

- Compute probability, various discrete and continuous probability distributions of random variables and their properties.
- Use the tools of statistics including measures of central tendency, correlation and regression.
- Use statistical methods for studying data samples.
- Use large sample and small sample tests.

Text Books:

1. S. Palaniammal, Probability and Random Processes, PHI learning private ltd., 2015.
2. S.C. Gupta, Fundamentals of Statistics, 7th Ed., Himalaya Publishing House, 2018.

Reference Books:

1. S.C. Gupta, V.K. Kapoor, Fundamentals of Mathematical Statistics, Sultan Chand & Sons, 2016.
2. Richards A Jonson, Irvin Miller and Johnson Freund, Probability and Statistics for Engineering, 9th Edition, PHI, 2011.
3. S. Ross, A First Course in Probability, 8th Ed., Pearson Education India, 2010.
4. M.R. Spiegel, J.J. Schiller and R.A. Srinivasan, Probability and Statistics, Schaum's Outlines, 2013.

Course Structure & Syllabus of B.Tech.– Petroleum Engineering

Applicable for Batch: 2021-25

1. Department offering the course	Petroleum and Energy Studies
2. Course Code	PEF201
3. Course Title	Geology and Geophysical Methods
4. Credits (L:T:P:C)	3:0:1:4
5. Contact Hours (L:T:P)	3:0:2
6. Prerequisites (if any)	None
7. Course Basket	DC

1. Course Summary

This course will introduce students to the physical geology and geomorphology of the various subsurface rock structures. It is important to understand the geological formations, classification and rock mineralogy of different lithology. Course covers a wide subject area, which includes paleontology, sedimentary petrology, plate tectonics etc.

2. Course Objectives

The students should be able to:

1. Learn about Igneous and Metamorphic rock types and their formation, classification of Sedimentary rocks, properties and the textures and structures.
2. Understand the principles and methods of Paleontology and the significance of microfossils in correlation of Petroliferous strata with emphasis on their application to the exploitation of Oil and Gas.
3. Understand the principles of Structural geology, folds, faults, joints and unconformities in relation to Petroleum reservoir and traps.
4. Learn about the various types of environments.

3. Course Outcomes

On successful completion of the course, students have the understanding of the following:

1. Understand of various topics of Applied Geology and get a better perspective of Petroleum exploration and concepts leading to a clearer understanding of Petroleum Engineering.
2. Understand the principles of exploration, evaluation, development, and recovery of hydrocarbons, and other fluids in various subsurface reservoirs.
3. Creates knowledge base which imparts the ability to work in the areas of exploration and exploitation of Hydrocarbons.
4. Develop skills for solving basic Petroleum related problems.
5. Develop into successful, socially and ethically responsible careers in the petroleum industry.

4. Curriculum Content

Unit 1:

Rock types: Igneous, Sedimentary and Metamorphic rock formation and their geological processes. Introduction to Sedimentary rocks: Rock cycle, Morphology and Textural properties. Sedimentary rocks classifications and their characteristics – Clastics and Non-Clastics.

Unit 2:

Geometric classification of folds, faults, joints, and unconformities; Field recognition of Fold and Faults. Sedimentary environment: Non-Marine, Mixed Marine and Marginal environments. Sedimentary facies and their applications.

Course Structure & Syllabus of B.Tech.– Petroleum Engineering

Applicable for Batch: 2021-25

Unit 3:

Introduction to Petroleum Geology; Organic and Inorganic origin of petroleum and their supporting theories. Introduction to source rock and reservoir rocks and cap rocks their formation processes and characteristics. Migration of petroleum; Kerogen studies: Formation, Maturation and types. Petroleum entrapment – process and types.

Unit 4:

Surface Indication of oil/ gas accumulation: accumulation parameters, regional and local structures. Gravity Survey: Measurement and anomaly detection, data correction and reduction. Magnetic survey: instruments and geo-magnetic anomalies, data correction and reduction. Electrical method: resistivity survey and equipment for measurement.

Unit- 5:

Seismic Survey: Type, Methodology of refraction profiling. Field survey arrangements. Recoding instruments. Data processing and interpretation with application in identification of structures. Vertical seismic profiling. 3-D data acquisition and interpretation.

List of Experiments

1. Identification of Mineral Hand Specimen
(i) Quartz (ii) Gypsum (iii) Beryl (iv) Garnet (v) Serpentine (vi) Dolomite (vii) Talc (viii) Pyroxene (ix) Kyanite (x) Orthoclase Feldspar (xi) Plagioclase (xii) Muscovite (xiii) Biotite (xiv) Calcite
2. Identification of Igneous rock in Hand Specimen
(i) Garnet (ii) Basalt (iii) Rhyolite (iv) Dolerite (v) Diorite
3. Identification of sedimentary rocks in Hand Specimen
(i) Sandstone (ii) Arkose (iii) Limestone (iv) Shale (v) Mudstone
4. Identification of metamorphic rocks in Hand Specimen
(i) Quartzite (ii) Marble (iii) Schist (iv) Gneiss (v) Slate
5. Identification of Mineral in thin section
(i) Quartz (ii) Feldspar (iii) Muscovite (iv) Biotite (v) Hornblende (vi) Pyroxene (vii) Olivine (viii) Pyrite (ix) Garnet
6. Measurement of dip and strike
7. Understanding of concept of contour map
8. Understanding of structural map

Textbook(s):

1. Parbin Singh; Engineering and General Geology;, Katson Publication House, 1987.
2. Sam Boggs. Jr.; Principles of Sedimentology & Stratigraphy; Pearson; 2011.
3. Leverson; Geology of Petroleum; Elsevier; 2006.

Reference Books:

1. Bhagwan Sahay; Petroleum Exploration and Exploitation Practices; Allied Publishers; 2001.
2. Richard C. Selley; Elements of Petroleum Geology; Elsevier; 1997.
3. Marland P. Billings; Structural Geology; Prentice-Hall; 1972.

Course Structure & Syllabus of B.Tech.– Petroleum Engineering

Applicable for Batch: 2021-25

1. Department offering the course	Petroleum and Energy Studies
2. Course Code	PEF202
3. Course Title	Chemical Thermodynamics
4. Credits (L:T:P:C)	3:1:0:4
5. Contact Hours (L:T:P)	3:1:0
6. Prerequisites (if any)	None
7. Course Basket	

8. Course Summary

The course Chemical thermodynamics deals with of how heat and work relate to each other both in changes of state and in chemical reactions. Key principles of chemical thermodynamics include systems, the laws of thermodynamics, and the four state functions, enthalpy, entropy, internal energy, free energy, chemical potential, phase equilibria; mixtures, solutions, colligative properties and chemical reaction equilibrium; Boltzmann's distribution law, ensembles and partition functions. Numerical calculations of thermodynamic properties.

9. Course Objectives

1. Be able to understand the basic thermodynamic terminology and scope, thermodynamic laws and their applicability and limitations.
2. To understand the various thermodynamics correlation and able to calculate the changes in U, H, S and G for ideal gases and also for non-ideal gases.
3. To understand the concept of partial molar properties, phase equilibria, fugacity, phase rule.
4. Understand the working principle and performance of refrigerators and heat pumps.

10. Course Outcomes

On successful completion of the course, students will be able to achieve the following:

1. Students gain knowledge about thermodynamics laws and their limitations, Also students understand the various equation of state and their significance.
2. Students understand the concept of partial molar properties, phase equilibria, ideal and non-ideal solution, fugacity, phase rule and calculations.
3. Students learn about various thermodynamics correlation and also learn about how to calculate thermodynamics properties
4. Select an appropriate equation of state for representing the P -V-T behavior of gases and/or liquids.
5. Students gain knowledge about types of compressor, their uses, working principle and performance of refrigerators and heat pump

11. Curriculum Content

Unit 1: Laws of Thermodynamics and Basic concept

Introductory Concepts of Thermodynamic Systems and variables, Work, Heat, Internal Energy, Thermodynamic Equilibrium, Reversible and Irreversible Processes; Phase-Rule; Significance of Chemical Engineering Thermodynamics. Equations of State and Generalized Correlations for Prediction of Volumetric Properties of Fluids. First Law: Closed and Open Systems, Second law and Entropy; Entropy Balance and Availability, Isentropic Efficiency. Maxwell Relations and Fluid Properties Estimation, Application to Flow Processes.

Unit 2: Thermodynamics of Gases and Liquid Hydrocarbons

Force energy, work function, Mollier diagram, perfect and imperfect gaseous mixtures. Equation of state, Law of corresponding states, Joule-Thompson effect, Arrhenius equation, Activation energy, Fugacity and fugacity coefficient, Lewis fugacity rules. Third law of thermodynamics.

Unit 3: Solution Thermodynamics

Vapour-liquid equilibria, partial molar properties, chemical potential, Raoult's Law and Henry's Law. ideal and non-ideal solutions, activity and activity coefficients.

Course Structure & Syllabus of B.Tech.– Petroleum Engineering

Applicable for Batch: 2021-25

Unit 4: Thermodynamic properties and VLE from equations of state

Gibbs – Duhem equation, Gibbs's adsorption equation. Phase rule: Single, two and multicomponent system. Phase behavior, Phase equilibria calculations. Ternary and pseudo-ternary phase diagrams, Liquid-Liquid Equilibria, Solid – Liquid Equilibria, Solid – Vapour Equilibria

Unit- 5: Chemical reaction equilibria

Chemical Reaction Equilibrium: Homogeneous and Heterogeneous reactions; Multi-reaction Equilibria

Textbook(s)

1. Smith J.M., Ness, H.C., Abbott, M., Bhatt, B; Introduction to Chemical Engineering Thermodynamics; McGraw-Hill; 2009.
2. Narayanan, K.V.; Chemical Engineering Thermodynamics; PHI Learning Private Ltd., 2013.

Reference Books

1. Dodge, B.F.; Chemical Engineering Thermodynamics; McGraw-Hill Book Co.
2. Abbott, VanNess, H.C.; Schaum Outline of Theory and Problems of Thermodynamics, McGraw-Hill International Book Co., Singapore, 1981.

Course Structure & Syllabus of B.Tech.– Petroleum Engineering

Applicable for Batch: 2021-25

1. Department offering the course	Petroleum & Energy Studies
2. Course Code	PEF203
3. Course Title	Drilling Technology
4. Credits (L:T:P:C)	3:0:1:4
5. Contact Hours (L:T:P)	3:0:2
6. Prerequisites (if any)	None
7. Course Basket	DC

1. Course Summary

Oil & Gas Well Drilling Technology will cover introduction of rig components. Further the course covers drilling aspects such as design of drill string; this course will also provide an insight to cementing operations along with introduction to directional drilling.

2. Course Objectives

The students should be able to:

1. Understand about the principles of drilling rig and drilling fluid system.
2. Understand well control and mitigation of drilling problems as well as gain sound understanding of drilling logs.

3. Course Outcomes

On successful completion of the course, students have the understanding of the following:

1. Understand rig power system, hoisting system, rotary system, and circulation system.
2. Identify, formulate, and solve engineering problems related to drilling fluids.
3. Design simple casing and design cement slurry for cementation.
4. Understand of well control equipment and operations.
5. Identify and mitigate wellbore problems and understand drilling logs.

4. Curriculum Content

UNIT – 1:

Introduction to Drilling Rig system and its components (Hoisting, circulation and Rotary system). Casing and drill string components. Rock bits (Drag, Roller cutter and PDC, etc.), Rock failure mechanism of bits and operational characteristics, optimization of bit hydraulics, hydraulic horse power calculation. Formation integrity test. Introduction to Directional drilling.

UNIT – 2:

Drilling Fluids: functions of drilling fluids, clay chemistry, types of drilling fluids, drilling fluid additives, rheological model.

UNIT – 3:

Oil-well cements: composition, cementing equipment cement-slurry design and downhole displacement processes.

UNIT – 4:

Causes of kicks, kick identification, Annular pressure prediction, Surface warning Signals, Wellbore Mechanics, Unsound Well control Techniques, Primary and Secondary well control, Shut in procedures.

Course Structure & Syllabus of B.Tech.– Petroleum Engineering

Applicable for Batch: 2021-25

UNIT – 5:

Wellbore problems: differential sticking, mechanical sticking, Parting the pipe string, fishing and lost circulation.

Drilling Log: Temperature log, Radioactive Tracer, stuck pipe log, Cement bond log and Variable Density log.

List of Experiments:

1. To find out plastic viscosity, yield point and gel strength using Fann Viscometer
2. To find of sand content in drilling mud
3. To find out mud weight of drilling fluid using Mud Balance
4. To find out Funnel Viscosity of drilling mud using Marsh Funnel
5. To determine Filter Cake and Fluid loss in drilling mud
6. To determine Resistivity of drilling mud
7. To determine surface tension and interfacial tension using surface tensionmeter

Text book [TB]:

1. Neal J. Adams; Drilling Engineering-A complete well planning approach; PennWell publishing Company; 1985.
2. Carl Gatlin; Drilling Well Completions; PHI; 1965.

Reference books [RB]:

1. Adam T. Bourgyne Jr., Keith K. Milheim; Applied Drilling Engineering; SPE Series; 1986.
2. S.S. Rahman, G.V. Chilingarian; Casing design theory and practice; Elsevier; 1995.

Course Structure & Syllabus of B.Tech.– Petroleum Engineering

Applicable for Batch: 2021-25

1. Department offering the course	Petroleum and Energy Studies
2. Course Code	PEF204
3. Course Title	Fluid Mechanics
4. Credits (L:T:P:C)	3:0:1:4
5. Contact Hours (L:T:P)	3:0:2
6. Prerequisites (if any)	None
7. Course Basket	

8. Course Summary

This course will offer basic knowledge on fluid statics, dynamics and hydraulic machines. The student will understand laws of fluid mechanics and evaluate pressure, velocity and acceleration fields for various fluid flows and performance parameters for hydraulic machinery.

9. Course Objectives

The students should be able to:

1. Understand about the principles of fluid mechanics.
2. Understand application of fluid mechanics in different domain of physics.

10. Course Outcomes

On successful completion of the course, students have the understanding of the following:

1. Develop better understanding of fluid behavior, fluid flow through the pipes, flow through porous media, various fluid properties and their relation, various types of pumping equipment petroleum industry.
2. Understand subjects like computational fluid dynamics along with better employment opportunity.
3. Understand stress strain relationship in fluids, classify their behavior and force analysis in static system.
4. Determine and analyse the performance aspects of fluid machinery specially for turbine, centrifugal pump and reciprocating pumps.
5. Be able to describe function of flow metering devices and apply bernoulli's equation to determine the performance of flow metering devices.

11. Curriculum Content

Unit 1:

Newtonian and non-Newtonian fluids. Incompressible and compressible flow. Two-phase flow. Friction factor estimation. Straight pipe bends, elbows, converging diverging section.

Unit 2:

Fluid pressure measurement. Piezometers, Manometers, Flow of fluid in pipes and flat surfaces.

Unit 3:

One and two dimensional flow equations. Bernoulli's equation, application, venturimeter, orifice meter. Equivalent length. Slurry transport.

Unit 4:

Pumps: Types, reciprocating and rotary pumps, construction details, performance characteristics. Single & multistage operation. Turbine pumps: multistage turbine pumps.

Unit- 5:

Compressors: Types, Rotary and centrifugal. Single stage and multi stage. Construction details and performance characteristics.

List of Experiments

1. To determine the coefficient of discharge C_d , velocity C_v , and contraction C_c of various types of orifices

Course Structure & Syllabus of B.Tech.– Petroleum Engineering

Applicable for Batch: 2021-25

2. Determine of discharge coefficients of: V-notch, Rectangular notch
3. To determine the minor head loss coefficient for different pipe fittings.
4. To study the variation of friction factor f . For turbulent flow in rough and smooth commercial pipes
5. To obtain the Reynolds number in different flow conditions.
6. To calibrate Venturimeter and to study the variation of coefficient of discharge with the Reynolds number.
7. To calibrate an orifice meter and to study the variation of coefficient of discharge with the Reynolds number
8. To verify the Bernoulli's theorem experimentally.
9. To determine Meta centric height of a floating body
10. To determine the efficiency of centrifugal pump

Textbook(s):

1. R.K. Bansal; Fluid Mechanics; Laxmi Publication; 2005.
2. P.N Modi and Dr S.M Seth; Hydraulics and fluid mechanics including hydraulics machines; Standard Book House; 1960.

Reference Books

1. Frank M. White; Fluid Mechanics; Mc Graw Hills; 2017.
2. Cengel and Cimbala; Fluid mechanics; McGraw Hills; 2017.

Course Structure & Syllabus of B.Tech.– Petroleum Engineering

Applicable for Batch: 2021-25

1. Department offering the course	Petroleum and Energy Studies
2. Course Code	PEF211
3. Course Title	Heat and Mass Transfer Process
4. Credits (L:T:P:C)	3:0:1:4
5. Contact Hours (L:T:P)	3:0:2
6. Prerequisites (if any)	PEF202
7. Course Basket	

8. Course Summary

The subject covers the fundamentals and basic concepts of separation and purification of mass through its transfer from one phase to the other. This course is also designed to introduce a basic study of the phenomena of heat transfer, to develop methodologies for solving a wide variety of practical engineering problems, and to provide useful information concerning the performance and design of particular systems and processes.

9. Course Objectives

The objective of this course is to introduce the basic principles of mass transfer and how to quantify, formulate, and solve engineering problems involving different mass transfer operations like diffusion and distillation. The objective of this course is to introduce the basic principles of heat transfer and how to quantify, formulate, and solve engineering problems involving different heat transfer modes like conduction, convection and radiation. Further, the design of heat exchangers, evaporators are the inherent objectives of the course. To demonstrate that how to apply mass balances and its transfer and analyze systems.

10. Course Outcomes

On successful completion of the course, students will be able to achieve the following:

1. To classify and use the accurate engineering correlations of diffusion and mass transfer coefficients to model a separation process.
2. To investigate a multi-stage equilibrium separation processes, simultaneous phase equilibrium and mass balances in continuous separation distillation.
3. Mathematically formulate and analyze heat transfer system by conduction and convection mode
4. Able to analyze radiative heat transfer system
5. Design and analyze the performance of heat exchangers and evaporators.

11. Curriculum Content

Unit 1: Diffusion

Molecular and turbulent diffusion, diffusion coefficient, Fick's Law of diffusion, Dependence of diffusion coefficient on temperature, pressure and composition.

Unit 2: Distillation

Vapour-liquid equilibrium and enthalpy concentration diagrams; Principles of distillation; Batch distillation with and without reflux; Steam distillation; Fractionating columns; Calculation of number of plates by McCabe-Thiele; Feed plate location; Optimum reflux; Open steam; Bubble cap tray, sieve tray, valve tray and packed columns; Calculation of column diameter; Entrainment; Hold-up; Plate efficiency; Principles of azeotropic and extractive distillations.

Unit 3: Introduction to Heat Transfer and Steady state heat transfer by conduction, convection

Heat Transfer Modes: Conduction, Convection And Radiation; Basic Concepts of Conduction In Solids; Liquids And Gases; Fourier Law of Heat Conduction; Material Properties of Importance In Heat Transfer: Thermal Conductivity, Specific Heat Capacity. General Equation of Heat Conduction Through Plane And Composite Walls; Cylinders and Spheres Critical and Optimum Insulation Thickness. Convection: Principle of heat flow in fluids and concept of heat transfer coefficient; Individual and

Course Structure & Syllabus of B.Tech.– Petroleum Engineering

Applicable for Batch: 2021-25

overall heat transfer coefficient. concept of fins; Fin efficiency; Forced Convective Heat Transfer; Heat Transfer by Natural Convection

Unit 4: Radiation Heat Transfer

Radiation heat transfer: Laws of Radiation; Shape factor; Radiation heat exchange between two long parallel plates and concentric cylinders, Radiation shield. Boiling; Boiling regimes; condensation; dropwise and film wise condensation

Unit- 5: Heat Exchanger analysis and design Evaporators

Heat Exchange Equipment: Construction Details; Operating Characteristics: Shell & Tube; Double Pipe; Plate & Frame Heat Exchangers; LMTD Correction Factor; Individual Heat Transfer Coefficient. Evaporators: Concentration; Foaming; Degradation Due To High Temperature; Scaling; Natural Circulation Evaporator; Forced Circulation Evaporator; Falling Film Evaporator; Performance Of Steam Heated Tubular Evaporators; Capacity And Economy; Boiling Point Elevation.

List of Practicals:

1. Steady state heat transfer through a composite wall
2. Temperature distribution through a fin under free and forced convection.
3. Parallel flow and counter flow double pipe heat exchanger
4. To obtain emissivity of an unknown plate using Emissivity Apparatus
5. Study of organic vapour-air diffusion
6. Study of packed bed distillation column
7. Study of sieve tray distillation column
8. Study of vapour-liquid Equilibrium

Textbook(s)

1. McCabe, W.L., Smith, J.C. and Harriott, P.; Unit Operations of Chemical Engineering; McGraw-Hill; 2001.
2. Treybal, R. E.; Mass Transfer Operations; McGraw-Hill; 1981.
3. Kern, D.Q.; Process Heat Transfer; McGraw-Hill; 1965.

Reference Books

1. Hines, A.L. and Maddox, R.N.; Mass Transfer Fundamentals and Applications; Prentice Hall; 2000.
2. Skelland, A.H.P.; Diffusional Mass Transfer; John Wiley & Sons; 1985.
3. Sherwood, T.K, Pigford, R.L., and Wilkes, C.R; Mass Transfer; McGraw Hill; 1975.

Course Structure & Syllabus of B.Tech.– Petroleum Engineering

Applicable for Batch: 2021-25

1. Department offering the course	Petroleum & Energy Studies
2. Course Code	PEF212
3. Course Title	Formation Evaluation
4. Credits (L:T:P:C)	3:1:0:4
5. Contact Hours (L:T:P)	3:1:0
6. Prerequisites (if any)	PEF201
7. Course Basket	

8. Course Summary

Formation Evaluation will cover understanding of various methods direct and indirect method of formation evaluation. This course covers various logs such as SP, GammaRay, Acoustic, Neutron & Density log along with crossplots. After leaning logs students will interpret logs for evaluation of formation.

9. Course Objectives

This course will enable students to understand the different types of formation and fluids which are likely to appear during the course of petroleum operation by application of geophysical principles. A thorough knowledge will impart on various logs which are used for formation evaluation.

10. Course Outcomes

On successful completion of the course, students will be able to achieve the following:

1. Apply principles and practices of wire-line logs in formation and reservoir evaluation
2. Determine mineralogy, porosity and saturation in various lithologies
3. Examine various logging tools: advantages and limitations; read and comprehend different log responses; apply integrated log interpretation techniques in formation evaluation
4. Solve formation evaluation problems and demonstrate results
5. Diagnose the effect of down hole conditions on tool response and log quality

11. Curriculum Content

UNIT – 1:

Classification of logs, Downhole & surface logging equipment, Log presentation, repeatability and Calibration, logging environment and effect of temperature, pressure and depth;

UNIT – 2:

Direct methods: Conventional coring, side wall coring and core evaluation, mud and cutting analysis and significance. Indirect Methods: Application of MWD and LWD in formation evaluation, SP log: principles and application, Resistivity logs: principles; electrodes systems: Normal, lateral, latero logs; Non-electrode system: Induction log; principles and application. Geosteering principles.

UNIT – 3:

Resistivity departure curves, Acoustic logs, ultrasonic wave velocity propagation through formation and relevant factors: Wave amplitude and relevant factors; Stuck pipe and related logs, Cement quality evaluation: Cement bond log, cement bonding with casing and formation.

UNIT – 4:

Radioactivity Logs: Natural gamma-ray and neutron-log: Principles, system and application. Special logging methods: Casing inspection tools, formation micro scanner, NMR log. Logging high angle wells. Production logging, Tracer logging, temperature logging, spinner logging, Flow velocity tools. Noise tools, Fluid density measurements techniques.

Course Structure & Syllabus of B.Tech.– Petroleum Engineering

Applicable for Batch: 2021-25

UNIT – 5:

Interpretation and analysis: prediction of formation pressure on the basis of log analysis. Formation types, thickness and sequence construction; fluid saturation determination. Standard interpretation methods. Cross-plotting methods; neutron-density, sonic density, clean and shaly sand interpretation.

Text Books:

1. Theory, measurement and interpretation of well logs by Zaki Bassiouni
2. Basic Well Log Analysis For Geologists by George Asquith, Charles Gibson
3. Formation Evaluation. Edward J. Lynch. Harper and Row, New York, 1962
4. Geological Interpretation of Well Logs, the Paperback by Malcolm H Ride
5. Bhagwansahay., “Petroleum Exploration and Exploitation Practices” Allied Publishers, 2001.

Course Structure & Syllabus of B.Tech.– Petroleum Engineering

Applicable for Batch: 2021-25

1. Department offering the course	Petroleum and Energy Studies
2. Course Code	PEF214
3. Course Title	Petroleum Production Operations – I
4. Credits (L:T:P:C)	3:1:0:4
5. Contact Hours (L:T:P)	3:1:0
6. Prerequisites (if any)	PEF203
7. Course Basket	DC

1. Course Summary

This course will introduce students to the oil and gas well production system including the equipment that are being used and the diverse operations being carried out. The surface and sub-surface operations should be designed such that we produce optimally from the reservoir. The Nodal analysis at every node in the production system is done to optimize the well production. The selection and application of suitable artificial lift techniques will be discussed in this course for the depleted reservoirs along with various problems that are encountered during the operation and their remedial measures. The course also covers the fluid handling and separation system.

2. Course Objectives

The students should be able to:

1. Understand about the basic subsurface and surface production operations and equipment.
2. Understand Reservoir and well deliverability to optimize the production.
3. Understand the artificial lift methods to improve oil recovery from depleted reservoirs.

10. Course Outcomes

On successful completion of the course, students have the understanding of the following:

1. Understand production equipment and operations in oil and gas industry.
2. Design the production system to optimize the oil and gas recovery
3. Understand the working and application considerations sucker rod pumping system and gas lift system.
4. Understand the working and application considerations other artificial lift systems and select the best fit artificial lift for candidate well.
5. Understand the operations, types and mechanisms of separation system.

11. Curriculum Content

Unit 1: Well Equipment

Well Head Equipment, Christmas tree, Valves, Hangers, Flow Control Devices, Safety Devices and Packers; Well Completion Design: Completions Techniques.

Unit 2: Oil and Gas Production Optimization

Self-flow Well Characteristics, Inflow performance, Outflow performance, Multiphase flow in tubing and flow-lines, Wellhead and Choke performance; Nodal Analysis.

Unit 3: SRP and Gas Lift Systems

Introduction, Objectives and Classifications. Sucker Rod Pump: Surface and Sub-surface Working System, Classifications, Selection Criteria, Advantages and Disadvantages, Dynamometer System and its Applications. Gas Lift: Introduction, Classifications on the Basis of Installations and Applications, System Characteristics, Applications, System Advantages and Disadvantages.

Course Structure & Syllabus of B.Tech.– Petroleum Engineering

Applicable for Batch: 2021-25

Unit 4: Other Artificial Lifts

Introduction, Working Principle, Advantages and Disadvantages, and Selection Criterion of Electrical Submersible Pump, Progressive Cavity Pump, Hydraulic Pump, Plunger Lift. Common Problems Affecting Artificial Lift Selection.

Unit- 5: Separation System

Fluid Production Handling System; Separation: Introduction, Factors Affecting Separation and Separation Mechanism; Separators: Types, Components, Control Systems, Operation and Maintenance of Separators, Operational Problems, Safety Features of Separators.

Textbook(s):

1. Thomas O. Allen & Alan P. Roberts ; Production Operations Vol.- 1 & Vol. 2; Oil and Gas consultants international; 1982.
2. D. Perrin; Well Completion and Servicing; Technip; 1999.
3. Kermit E. Brown, H. Dale Beggs; The Technology of Artificial Lift Methods, Vol - 1; Pennwell Books; 1977.

Reference Book(s):

1. Ken Arnold & Maurice Stewart; Surface production Operation Vol.-1 & Vol. 2; Gulf publishing compony; 1989.
2. Michael J. Economides, A. Daniel Hill and Christine Ehlig- Economides; Petroleum Production Systems; Prentice hall Petroleum Engineering Series; 1994.

Course Structure & Syllabus of B.Tech.– Petroleum Engineering

Applicable for Batch: 2021-25

1. Department offering the course	Petroleum and Energy Studies
2. Course Code	PEF216
3. Course Title	Reservoir Engineering
4. Credits (L:T:P:C)	3:0:1:4
5. Contact Hours (L:T:P)	3:0:2
6. Prerequisites (if any)	PEF201
7. Course Basket	DC

1. Course Summary

This course will introduce students to the basics of reservoir engineering. It will cover the role of reservoir engineers in exploration and production. Students will also learn about reservoir fluid and rock properties, determine the reservoir pressure, engineering applications and the fundamental concepts of fluid flow in porous media. Multiphase situations, types of oil and gas reservoirs, reservoir drive mechanisms, the basics of material balance and decline curve analysis, and reserve definitions will also be discussed.

2. Course Objectives

The students will be able to:

1. Determine the rock properties such as Porosity, permeability and saturation etc.
2. Calculations on PVT analysis of the specific reservoir of various sands.
3. Learn about the steady and unsteady state conditions.
4. Estimation the reserves of various sands of the reservoir from different well data.
5. Calculate the recovery factor from different drives indices.

3. Course Outcomes

On successful completion of the course, students have the understanding of the following:

1. To know in the basic concepts like PVT analysis for oil.
2. To be able to identify and design reservoir flow models.
3. To understand Material balance equation for oil reservoir, Darcy's law and applications.
4. To understand Reservoir pressure determination and estimation for stabilized flow conditions.
5. To make them suitable as reservoir engineers for petroleum industry.

4. Curriculum Content

UNIT 1:

Reservoir rock properties: Measurement of Porosity, Permeability and Capillary pressure, interfacial tension measurement; evaluation. Parallel and series bed systems. Fluid saturation, effective and relative permeability, wettability, evaluations and significance, WOC, GOC and its evaluations.

UNIT 2:

Reservoir Fluid System: Gas and Oil property of reservoir, Volumetric and phase behavior of multi-component oil/ gas system. Formation volume factor for oil and gas, viscosity, reservoir fluid sampling, flash liberation and differential liberation test, PVT properties: measurement, estimation and application.

UNIT 3:

Fluid flow through Porous media: Darcy's law, single and multi-phase system, linear, radial and spherical flow, steady state flow. Flow through fracture, GOR and WOR equations.

Course Structure & Syllabus of B.Tech.– Petroleum Engineering

Applicable for Batch: 2021-25

UNIT 4:

Reservoir pressure determination: Pressure measurement techniques, Bottom-hole pressure gauges, determination of reservoir pressure, significance.

UNIT 5:

Reservoir drives: Depletion, water drive, gas cap drive, combination drive, and recovery factor. Reserve estimation: MBE, volumetric estimation, Decline curve analysis, Resource and reserve, SPE classification of reserve.

List of Experiments:

1. To determine the effective porosity.
2. To determine the water separatability of petro oil.
3. To determine the permeability of the given core sample by Ruska Liquid Permeameter.
4. To determine the permeability of the given core sample by Gas Permeameter.
5. To study the properties of core sample.
6. To plug the core of desired size from the rock sample.

Text book [TB]:

1. L.P. Dake; Fundamentals of Reservoir Engineering; Elsevier Science; 1978.
2. Tarek Ahmed; Reservoir Engineering Handbook; Gulf Professional Publishing, 2006.

Reference books [RB]:

1. B. C. Craft, M. Hawkins; Applied Petroleum Reservoir Engineering; Prentice Hall; 2014.
2. Rene Cosse; Basic Reservoir Engineering; Editions Technip; 1993.
3. James W Amyx, Daniel M. Bass Jr., Robert L. Whiting; Petroleum Reservoir Engineering; McGraw Hill, 1960.

Course Structure & Syllabus of B.Tech.– Petroleum Engineering

Applicable for Batch: 2021-25

1. Department offering the course	Petroleum and Energy Studies
2. Course Code	PEF304
3. Course Title	Enhanced oil Recovery
4. Credits (L:T:P:C)	3:0:1:4
5. Contact Hours (L:T:P)	3:0:2
6. Prerequisites (if any)	PEF216
7. Course Basket	

8. Course Summary

This course will introduce students to the basics of reservoir engineering. It will cover the role of reservoir engineers in exploration and production. Students will also learn about reservoir fluid and rock properties, engineering applications and the fundamental concepts of fluid flow in porous media. Multiphase situations, types of oil and gas reservoirs, reservoir drive mechanisms, the basics of material balance and decline curve analysis, and reserve definitions will also be discussed.

9. Course Objectives

The students will be able to:

1. Calculate the PVT analysis parameters of the specific reservoir of various sands.
2. Estimate the reserves of various sands of the reservoir from different well data.
3. Calculate the formation damage and recovery factor from different drives and can propose suitable stimulation operations to reverse the lease

10. Course Outcomes

On successful completion of the course, students have the understanding of the following:

1. To know in the basic concepts like PVT analysis for oil.
2. To be able to identify and design reservoir flow models.
3. To understand Material balance equation for oil reservoir, Darcy's law and applications.
4. To understand Reservoir pressure determination and estimation for stabilized flow conditions.
5. To make them suitable as reservoir engineers for petroleum industry.

11. Curriculum Content

UNIT 1:

Reservoir rock properties: Measurement of Porosity, Permeability and Capillary pressure, interfacial tension measurement; evaluation. Parallel and series bed systems. Fluid saturation, effective and relative permeability, wettability, evaluations and significance

UNIT 2:

Reservoir Fluid System: Volumetric and phase behavior of multi-component oil/ gas system. Formation volume factor for oil and gas, viscosity, reservoir fluid sampling, PVT properties: measurement, estimation and application

UNIT 3:

Fluid flow through Porous media: Darcy's law, single and multi-phase system, linear, radial and spherical flow, steady state flow. Flow through fracture, GOR and WOR equations

UNIT 4:

Reservoir pressure determination: Pressure measurement techniques, Bottom hole pressure gauges, determination of reservoir pressure, significance

Course Structure & Syllabus of B.Tech.– Petroleum Engineering

Applicable for Batch: 2021-25

UNIT 5:

Reservoir drives: Depletion, water drive, gas cap drive, combination drive, and recovery factor. Reserve estimation: MBE, volumetric estimation, Decline curve analysis, Resource and reserve, SPE classification of reserve

List of Experiments:

1. To determine the effective porosity
2. To determine the water separatability of petro oil
3. To determine the permeability of the given core sample
4. To determine the permeability of the given core sample
5. To study the properties of core sample
6. To plug the core of desired size from the rock sample

Text book [TB]:

1. L.P. Dake; Fundamentals of Reservoir Engineering; Elsevier Science; 1978.
2. Tarek Ahmed; Reservoir Engineering Handbook; Gulf Professional Publishing, 2006.

Reference books [RB]:

1. B. C. Craft, M. Hawkins; Applied Petroleum Reservoir Engineering; Prentice Hall; 2014.
2. Rene Cosse; Basic Reservoir Engineering; Editions Technip; 1993.
3. James W Amyx, Daniel M. Bass Jr., Robert L. Whiting; Petroleum Reservoir Engineering; McGraw Hill, 1960.

Course Structure & Syllabus of B.Tech.– Petroleum Engineering

Applicable for Batch: 2021-25

1. Department offering the course	Petroleum and Energy Studies
2. Course Code	PEF302
3. Course Title	Petroleum Production Operations – II
4. Credits (L:T:P:C)	3:1:0:4
5. Contact Hours (L:T:P)	3:1:0
6. Prerequisites (if any)	PEF214
7. Course Basket	DC

1. Course Summary

The course deals with Sick well analysis, sand control, formation damages, well servicing and work over operations, well stimulation, storage procedure, vapour control and transportation system. The main objective of this course is to provide basic knowledge of production operations during production in the oil and gas wells.

2. Course Objectives

The objective of this course is to familiarize the students with the problems encountered during production and their remedial measures as well as well stimulation techniques, and provide the knowledge of storage and transportation facilities.

3. Course Outcomes

On successful completion of the course, students will have the understanding of the following:

1. Identify and mitigate the problems encountered during production operations.
2. Understand the Work-over operations and perform well intervention jobs to improve productivity.
3. Understand the Well Stimulation operations and Design hydraulic fracturing jobs for the candidate well.
4. Design matrix acidization and acid fracturing jobs for the candidate well.
5. Understand the storage facilities, fluid conditioning and overview of transportation system.

4. Curriculum Content

UNIT 1:

Sick Well Analysis; Water and Gas Shut Off: Extraneous Gas and Water Entry into Wellbore, Source Identification, and Control Measures. Sand production: Causes, Effects, Sand Control Techniques, Gravel Size Selection, Gravel Packing. Formation Damage: Sources, Effects, Mechanisms and Remedial Measures. Corrosion and Scale Formation: Causes, Effects, Prevention, and Control Measures. Wax and Asphaltene Control.

UNIT 2:

Well Subduing; Well Activation. Well Servicing and Workover: Introduction, Problem Identification, Workover Operations, Workover Equipment; Workover and Completion Fluids; Safety Procedures; Workover Rig Selection; Rigless Intervention: Snubbing Unit and Coiled Tubing Unit; Planning and Economics.

UNIT 3:

Well stimulation: Introduction. Hydraulic Fracturing: Dynamic fracture Geometry: Orientation, vertical, horizontal and penny-shaped. Hydraulic fracturing model (i.e., Radial Fracture model, PKN Model and KGD model) Parameters involved in hydraulic fracturing, Entry hole diameter

Course Structure & Syllabus of B.Tech.– Petroleum Engineering

Applicable for Batch: 2021-25

Perforation for Hydraulic fracturing, Fluid loss, fracture conductivity.

UNIT 4

Well Acidization: Methods, Well Stimulation acids, Acid additives, Rates of reaction, Factors controlling the acid reaction rates, Sandstone and Carbonate Acidization. Design consideration in Matrix acidizing, Retardation of acid. Acid fracturing.

UNIT 5

Storage: Purpose, Classification (Offshore / Onshore / Underground), Types of Tanks, Tank Selection, Tank construction, Tank Inspection and Maintenance, Operation and Safety of Tanks. Vapor Control: Purpose, Factors Contributing to Vapor Losses, Conservation Measures, Evaporation Prevention, Vapor Recovery System. De-Emulsification, Dehydration and Desalination of Crudes; Produced Water Treating System. Oil and Gas Transportation.

Text book [TB]:

1. Thomas O. Allen & Alan P. Roberts ; Production Operations Vol.- 1 & Vol. 2; Oil and Gas consultants international; 1982.
2. Ken Arnold & Maurice Stewart; Surface production Operation Vol.-1 & Vol. 2; Gulf publishing compony; 1989.

Reference books [RB]:

1. D. Perrin; Well Completion and Servicing; Technip; 1999.
2. Michael J. Economides, A. Daniel Hill and Christine Ehlig- Economides; Petroleum Production Systems; Prentice hall Petroleum Engineering Series; 1994.
3. Reservoir stimulation by Ahmed S. Abou-Sayed

Course Structure & Syllabus of B.Tech.– Petroleum Engineering

Applicable for Batch: 2021-25

1. Department offering the course	Petroleum and Energy Studies
2. Course Code	PEF303
3. Course Title	Health, Safety and Environment in Petroleum Industry
4. Credits (L:T:P:C)	3:1:0:4
5. Contact Hours (L:T:P)	3:1:0
6. Prerequisites (if any)	PEF214
7. Course Basket	

8. Course Summary

This course will introduce students to the oil and gas industry objectives for work with health, safety and environment (HSE) and regulations concerning HSE work. For both onshore and offshore operations of oil and gas wells there are various guidelines followed under HSE norms. Students will also learn regarding various waste treatment methods and oil spill control techniques in land and offshore environment.

9. Course Objectives

The students should be able to:

1. Understand different HSE responsibilities and reporting of HSE problems and discrepancies.
2. Inculcate the safety culture in personal and professional life.
3. Understand various hazard identification and risk assessment studies.

10. Course Outcomes

On successful completion of the course, students have the understanding of the following:

1. Comprehend different industry hazards and plane safety.
2. Recognize modes of transportation of oil and gas, and safety measures in transportation
3. Realize procedure of safety auditing and prepare safety reports
4. Apply concepts of risk analysis to develop probabilistic assessment.
5. Be aware of the waste treatment and disposal.

11. Curriculum Content

Unit 1:

Well Integrity & Environmental control: Mechanism of cement set failures, Improved cementing for annular integrity, integrity of injection wells, sustained casing pressure, rig less and rig intervention for SCP isolation. Well barriers and verification during drilling & production operations (NORSOK 10D)

Unit 2:

Environmental control of drilling fluids and produced water: Control of drilling fluid toxicity, testing and low toxicity substitutes, SBM, cuttings disposal and de-oiling. Health hazard, Toxicity, physiological, asphyxiation, respiration and skin effects when using completion fluids. Effect of sour gases (H₂S and CO) on human health.

Unit 3:

Environment Health and Safety Management: Oil-spill control. Environmental impact assessment. Waste disposal and treatment in land and offshore environment, produced water disposal, accidental discharge, drilling waste, OSPAR, regulatory control and policies.

Unit 4:

Well control during drilling, completion and production operations, containment and casing design, relief well planning, oil spill and response management, Manual and automatic shutdown systems, blow down systems. Gas leakage, fire detection and suppression systems.

Unit- 5:

Control of atmospheric, aqueous emissions in refineries. Soil and groundwater protection during

Course Structure & Syllabus of B.Tech.– Petroleum Engineering

Applicable for Batch: 2021-25

petroleum operations. Control of solid wastes, treatment and disposal, recycling to minimize waste and re-use.

Textbook(s):

1. OrzuOrszulik; Environmental Technology in oil Industry; Springer; 1996.
2. Reis, J.C.; Environmental control in Petroleum Engineering; Gulf publications; 1998.

Reference Books

1. Boyce, A., “Introduction to Environmental Technology”, John Wiley and Sons, 1996.
2. C V Efobi; Site safety handbook for the petroleum industry; Partridge Publishing; 2015.

Course Structure & Syllabus of B.Tech.– Petroleum Engineering

Applicable for Batch: 2021-25

1. Department offering the course	Petroleum and Energy Studies
2. Course Code	PEF313
3. Course Title	Reservoir Simulation
4. Credits (L:T:P:C)	3:0:2:4
5. Contact Hours (L:T:P)	3:0:2
6. Prerequisites (if any)	PEF216
7. Course Basket	DC

1. Course Summary

This course compacts with theoretical and working understanding of reservoir simulation models of unpredictable complications. Apply the numerical methods for the solution of simple and difficult reservoir simulation models. Highlighting will be towards the general approaches such as direct solution and iterative solution methods. Parametric analysis of reservoir simulation models.

2. Course Objectives

Understand the basics of reservoir simulation and its bigger picture and to understand the physical and mathematical principles used in simulating the reservoirs.

3. Course Outcomes

On successful completion of the course, students have the understanding of the following:

1. Understand and evaluate the basic data required for construction of a reservoir simulation model.
2. Develop awareness of the mathematical techniques at the back-end that are used in simulation.
3. Display knowledge of various types of boundary conditions and their impact in simulation.
4. Create a replica for reservoir environment.
5. Develop production plan for the field and Enhance the complexity of mathematical models to represent realistic reservoir conditions.

4. Curriculum Content

UNIT 1:

Introduction & Overview: Definition, Objectives and applications of reservoir simulation with brief overview of the system, Steps of the reservoir simulation.

Model types: Physical, Analog and mathematical, Single-phase, Multi-phase in one, Two and Three dimension mathematical model for reservoir fluid flow, Grid blocks and Grid orientation.

UNIT 2:

Model Equations: Black oil and composition models. Data Preparation: Rock, fluid, Mechanical, Production and Validation.

UNIT 3:

Solution Techniques: Analytical and Numerical methods, Explicit and Implicit methods of discretization, Finite difference and Linearization, Solution of simultaneous equations.

UNIT 4:

Stability criteria, Iterative methods, IMPES & IMPIS methods, Numerical dispersion, Grid and

Course Structure & Syllabus of B.Tech.– Petroleum Engineering

Applicable for Batch: 2021-25

time step size selection, History matching, Manual and automated system Reservoir performance using simulation approach.

UNIT 5:

Simulating special processes: Simulation of a reservoir using available commercial software for black oil, Briefly discuss other models such as compositional simulation, Miscible, Chemical and Polymer flooding, Thermal recovery processes, Capabilities and Limitations.

List of Experiments:

1. Introduction to Reservoir Modelling and Simulation Using CMG.
2. Grid Construction Using Builder.
3. Model Construction.
4. Well Representation in Simulator.
5. Static Modelling.
6. Incorporation of Historical Production Data into Model.
7. Dynamic Modelling and Validation.
8. Streamline simulation and History Matching.
9. Simulation Result Interpretation.

Text book [TB]:

1. T. Ertenim, J.H Abou-kassem and G.R. King; Basic Applied Reservoir Simulation; SPE Text book series; 2001.
2. Crichlow, Henry B.; Modern Reservoir Engineering: a simulation approach; Prentice Hall, 1977.

Reference books [RB]:

1. B. C. Craft, M. Hawkins; Applied Petroleum Reservoir Engineering; Prentice Hall; 2014.
2. Notes on reservoir simulation, Institute of Petroleum Engineering, Herriot-watt University; 2011.
3. J.R.Fanchi; Principles of Applied Reservoir Simulation; Gulf Publication; 2006.

Course Structure & Syllabus of B.Tech.– Petroleum Engineering

Applicable for Batch: 2021-25

1. Department offering the course	Petroleum and Energy Studies
2. Course Code	PEF312
3. Course Title	Oil and Gas Well Testing
4. Credits (L:T:P:C)	3:0:1:4
5. Contact Hours (L:T:P)	3:0:2
6. Prerequisites (if any)	PEF216
7. Course Basket	

8. Course Summary

This course will introduce students to the well testing methods for oil and gas wells in shut – in and flowing conditions. The students will be able to understand the flow equations and their solutions for different types of reservoir fluids and flow behaviours. The various well testing methods for oil and gas wells will be discussed along with their data acquisition, data processing and interpretation to obtain the well conditions and to create production plan accordingly. Other tests including drill stem test, interference test, reservoir limit test and injectivity test, etc. will be discussed to obtain the suitable parameters. This course shall avail students to identify and select the suitable method of well testing to meet the operational objectives.

9. Course Objectives

The students should be able to:

1. Identify and obtain the parameters for each testing method.
2. Identify and select the suitable method of well testing.
3. Impart the knowledge of fundamentals of well testing along with the field operations of data acquisition, data processing and interpretation to obtain the desired parameters.

10. Course Outcomes

On successful completion of the course, students will be able to:

1. Understand the need and concept of well testing.
2. Understand the concept of field data acquisition, processing and interpretation method of Build – up test for an oil well.
3. Understand the concept of field data acquisition, processing and interpretation method of Drawdown test for an oil well.
4. Understand the fundamentals of type curve analysis and gas well testing methods.
5. Identify and select the suitable method of well testing to meet operational objectives.

11. Curriculum Content

Unit 1: Introduction to Pressure Transient Tests

Objectives of Pressure Transient Testing; Types of Pressure Transient Tests; Flow of compressible fluid through porous media: Steady state, Unsteady state, Semi-steady State Fluid Flow Equations; Diffusivity Equation; Solutions to Diffusivity Equation; Horner's Approximation.

Unit 2: Build – Up Test

Ideal Pressure Build-up Test: Assumptions and Equations; Pressure Build-up Test Analysis: Permeability, Skin Factor, Initial Reservoir Pressure and Reservoir Drainage area; Actual Pressure Build-up Test; Effects and Duration of Afterflow; Well Damage and Stimulation; Gas Well Build-up Test Analysis.

Unit 3: Pressure Drawdown Test

Pressure Draw-down Test: Objectives, Assumptions and Equations; Constant Rate Drawdown Test Analysis: Formation Permeability, Skin Factor, Wellbore Storage, Reservoir Pore Volume and Radius of Investigation; Varying Rate Drawdown Test Analysis; Multirate Drawdown Test Analysis.

Unit 4: Gas Well Test and Type Curves

Fundamentals of Type curves; Ramey's Type Curve; McKinley's Type Curve; Gringarten et al Type Curve; Drawdown Test Analysis Using Type Curves; Pressure derivative; Gas well testing: Flow After

Course Structure & Syllabus of B.Tech.– Petroleum Engineering

Applicable for Batch: 2021-25

Flow Test, Isochronal Test, Modified Isochronal Test.

Unit- 5: Other Test Methods

Drill Stem Testing; Reservoir Limit Test; Injection and Fall-off Test; Interference Test; Pulse Test.

List of Experiments:

1. Introduction to the Oil and Gas Well Testing Lab.
2. Introduction to IHS Markit Well Test Software.
3. To determine the permeability and skin of a reservoir using Build-up test data for an oil well.
4. To determine the permeability and skin of a reservoir using Drawdown test data for an oil well.
5. To determine the Absolute Open Flow potential of a reservoir using Flow after flow test data for a gas well.
6. To determine the Absolute Open Flow potential of a reservoir using Isochronal test data for a gas well.
7. To determine the Absolute Open Flow potential of a reservoir using Modified Isochronal test data for a gas well.

Textbook(s)

1. John Lee; Well Testing; SPE of AIME Vol. 1; 1982.
2. Robert C. Earlougher Jr.; Advances in Well Test Analysis; SPE of AIME; 1977.

Reference Books

1. Dominique Bourdet ; Well Test Analysis: The Use of Advanced Interpretation Models; Elsevier; 2002.
2. Bath, England; Introduction to Well Testing; Schlumberger Wireline & Testing; 1998.
3. Ronald N. Horne; Modern Well Test Analysis – A Computer Aided Approach; Petroway, Inc; 1995.

Course Structure & Syllabus of B.Tech.– Petroleum Engineering

Applicable for Batch: 2021-25

1. Department offering the course	Petroleum and Energy Studies
2. Course Code	PEF341
3. Course Title	Petroleum Refining and Petrochemicals
4. Credits (L:T:P:C)	2:0:1:3
5. Contact Hours (L:T:P)	2:0:2
6. Prerequisites (if any)	None
7. Course Basket	

8. Course Summary

This course will introduce students about Crude oil Properties and characterization, different products obtained from crude oils i.e. LPG, Petrol, Diesel, LGO, HGO, LVGO, HVGO, fuel oil, wax, asphalt and bitumen and their properties and laboratory testing methods for characterization of these products. It involves topics related to description of different refining processes like crude oil distillation, catalytic cracking visbreaking, isomerization, catalytic reforming, isomerization, and coking, different petrochemicals obtained from refining operations and their uses and methods of production of petrochemicals.

9. Course Objectives

The students shall be able to:

1. Understand about various petroleum products and their testing methods, various petroleum refining processes and their significance.
2. Be aware about various petrochemical manufacturing processes and classification and uses of petrochemicals.
3. Understand about different lube oil processes

10. Course Outcomes

On successful completion of the course, students will be able to achieve the following:

1. The students will be able to get an overview of the petroleum refining processes, Petroleum Products and their testing methods with its significance.
2. The students will become exposed to information on distillation Operation and working principles of different equipment's used in distillation operations
3. Students gain knowledge about different refining processes with its importance.
4. Students learn about Deasphalting and dewaxing techniques for lube oil production, carbon black and coke production techniques.
5. The students will get an idea about the midstream process of the hydrocarbon cycle, Uses of different petrochemicals and their production methods.

11. Curriculum Content

UNIT 1

Overview of Petroleum refining processes. Crude oil evaluation (Based on Residue, Based on Key Fraction, Based on Characterization factor and correlation index) Evaluation methods for petroleum products like LPG, gasoline diesel, kerosene, Lubricating oil etc. choice of crude types for a product mix, various products with their boiling range, Uses of petroleum products

UNIT 2

Distillation system: pipe still heater, distillation column, heat exchangers, condenser, reflux control, pressure control; Atmospheric distillation system, vacuum distillation system.

UNIT 3

Other refining processes: Visbreaking, Thermal cracking, catalytic Cracking, catalytic reforming, alkylation, isomerization, hydrocracking, hydorfinishing

Course Structure & Syllabus of B.Tech.– Petroleum Engineering

Applicable for Batch: 2021-25

UNIT 4

Specialty products: Lube oil production, propane deasphalting, solvent extraction (Phenol Extraction, Furfural Extraction, Duo sol methods) dewaxing (Chilling and pressing, Propane Dewaxing, MEK Dewaxing etc.) coke and carbon black production (Delayed Coking and Fluid Coking), Types and Uses of coke.

UNIT 5

Status of Petrochemical industry in India, Main Building blocks of petroleum industry, Different chemical obtained from main building blocks, Petro-chemical feed stock: BTX, olefins Production: (Steam Cracking) method ethane and butane treated products from natural gas, Synthesis gas production, Storage and safety measures: Floating roof tanks, spherical storage vessels; fire safety measures.

List of Experiments

1. Study of ASTM distillation characteristics of various fuel
2. To study determination of Calorific Value of Fuels
3. Determination of flash point of oil sample using Abel Apparatus
4. Determination of flash point and fire point of a given oil sample using Cleveland Open cup Apparatus
5. Determination of % carbon residue content in Lubrication Oil
6. Determination of drop melting point of grease
7. Determination of pour & cloud point temperatures of samples
8. To determine the kinematic viscosity and absolute viscosity of the given lubrication oil using Redwood Viscometer-I
9. To determine the kinematic viscosity and absolute viscosity of the given lubrication oil using Redwood Viscometer-II
10. To determine the kinematic viscosity and absolute viscosity of the given lubrication oil Saybolt Viscometer
11. Determination of flash point of oil sample using Pensky Martens Apparatus
12. ASTM Distillation

Text book [TB]:

1. Mall I.D. “Petrochemical Process Technology”, Macmillan India Ltd,2007.
2. Gary J.H. and Handework G.E., “Petroleum Refining Technology and Economics”, Marcel Dekker, Inc., 1984.

Reference books [RB]:

1. B.K.BhaskaraRao, “Modern Petroleum Refining Processes”, Fifth Edition, Oxford and IBH Publishing Co. Pvt. Ltd. (2007).

Course Structure & Syllabus of B.Tech.– Petroleum Engineering

Applicable for Batch: 2021-25

1. Department offering the course	Petroleum and Energy Studies
2. Course Code	PEF342
3. Course Title	Petroleum Field Instrumentation and Control
4. Credits (L:T:P:C)	2:0:1:3
5. Contact Hours (L:T:P)	2:0:2
6. Prerequisites (if any)	None
7. Course Basket	

8. Course Summary

This course "Petroleum Field Instrumentation and Control" goes deeper into the various aspects of control engineering along with bringing out the theories and practical knowledge of control engineering. The topics cover introductory concepts, modeling considerations, dynamic behavior of chemical processes, stability aspects and design of feedback controller. Other topics which will be covered are control strategies such as feed-forward controller, cascade control structure, ratio control, split-range control, selective control and preliminary concepts of adaptive control. Even though the course is on first course of control engineering, the topics on multi-loop multivariable control will also be presented for completeness. Instrumentation part will consist of valve characteristics, various measuring devices, instrumentation symbols and introduction to P&ID.

9. Course Objectives

5. To learn the type of System, dynamics of physical systems, classification of control system, analysis and design objective.
6. To represent system by transfer function and block diagram reduction method and Mason's gain formula.
7. To learn time response analysis and demonstrate their knowledge to frequency response.
8. To learn stability analysis of system using Root locus and bode plot.
9. To learn the various instruments used for measuring flow, temperature, pressure and level.

10. Course Outcomes

On successful completion of the course, students will be able to achieve the following:

1. Able to analyse the application of Laplace Transformation in control system
2. Formulate mathematical model for physical systems and use standard test signals to identify performance characteristics of first and second-order systems
3. Apply root locus technique for stability analysis and analyse performance characteristics of system using Frequency response methods.
4. Able to understand the application of different controllers in the various chemical processes.
5. Able to understand the various instruments used for the measurement of process parameters.

11. Curriculum Content

Unit 1: Introductory concept

First principles model development of chemical processes, steady state and dynamic behaviour; linearization of nonlinear processes, Laplace Transform, initial and final value theorems.

Unit 2: Modeling Considerations and Dynamic behavior of Process

Solving algebraic equations and integration of ODEs. Concept of nonlinearity; linearization of nonlinear processes; deviation variables. Concept of Laplace Transform (LT); the LT of basic functions - step, impulse, pulse, ramp, exponential, integral, derivative, time delay; initial and final value theorems. Solution of differential equation using LT techniques - Partial fraction expansion, direct division. Dynamic response of a first order process, first order plus dead time process, second order process, pure capacitive process, pure dead time, higher order process. Interacting and non-interacting processes.

Course Structure & Syllabus of B.Tech.– Petroleum Engineering

Applicable for Batch: 2021-25

Unit 3: Dynamic behavior of Controller

Introduction to feedback control. Elements of Control loop - controller, measuring device, final control element, transmission lines, transducers, transmitters, block diagram. Concept of servo and regulatory problems. d. Selection of measured, manipulated and controlled variables. Types of controller - P, PI, PID, on-off. Effects of proportional, integral and derivative actions. Notion of stability - characteristic equation, RouthHurwitz criteria, root-locus analysis. Frequency response analysis - Bode plot. Controller Tuning: Cohen-Coon method, Ziegler-Nichols method.

Unit 4: Other Control Strategies

Feed forward controller - design with steady state model, design with dynamic model, combination of feed forward-feedback structure. Cascade control structure - analysis and design. Ratio control, split range control, selective control, override control, auctioneering control. Concepts of adaptive and inferential control.

Unit- 5: Process Instrumentation

Final Control Elements - Valve characteristics, thyristors. Measuring Devices for flow, temperature, pressure and level. Instrumentation symbols.

Textbook(s)

1. Stephanopoulos, G., Chemical Process Control: An Introduction to Theory and Practice ", Prentice-Hall, New Jersey, 1984.
2. Coughanowr, D. R. and L. B. Koppel, " Process systems Analysis and Control ", Mc-Graw-Hill, 2nd. Ed., 1991.
3. Luyben, W. L.," Process Modelling Simulation and Control for Chemical Engineers ", McGraw Hill, 1990.

Reference Books

1. "Process Control and Instrumentation", R. P. Vyas, Denett& Co.
2. "Industrial Instrumentation", Donald .P. Eckman, John Wiley & Sons Inc, New York.
3. "Industrial Instrumentation & Control", S. K. Singh, Tata McGraw-Hill Education.
4. "Process Instrumentation And Control", A. P. Kulkarni, NiraliPrakashan

Course Structure & Syllabus of B.Tech.– Petroleum Engineering

Applicable for Batch: 2021-25

1. Department offering the course	Petroleum and Energy Studies
2. Course Code	PEF343
3. Course Title	Numerical Methods
4. Credits (L:T:P:C)	3:0:0:3
5. Contact Hours (L:T:P)	3:0:0
6. Prerequisites (if any)	None
7. Course Basket	DE

1. Course Summary

This course deals with various numerical method viz, finite elements, finite difference methods which can be applied for reservoir modelling. Further, various simulation techniques, Iterative methods in this course will be helpful for reservoir simulation.

2. Course Objectives

The objective of this course is to explore complex systems through simple optimization, interpolation from the known to the unknown, linear algebra underlying systems of equations, ordinary differential equations to simulate systems, and stochastic simulation under random influences.

3. Course Outcomes

On successful completion of the course, students have the understanding of the following:

1. Understand and analyse finite difference methods.
2. To understand and analyse various equal and unequal interval halving methods.
3. Derive numerical methods for various mathematical operations and tasks, such as interpolation, differentiation, integration, the solution of linear and nonlinear equations.
4. Analyse and evaluate the Numerical Differentiation & Integration methods.
5. Evaluate and reiterate the linearization methods.

4. Curriculum Content

UNIT 1:

Errors and Finite Differences Error & their analysis, Computer arithmetic, Floating-point number operation. Finite differences: Difference operator, Difference tables, Factorial polynomials, Summation of series.

UNIT 2:

Interpolation Newton's formula, Gauss, Stirling's and Bessel's formula for equal interval, Lagrange's formula and Newton's divided difference formula for unequal interval.

UNIT 3:

Algebraic & Transcendental Equations Bisection method, Iteration method, False Position method, Newton-Raphson method, Rate of convergence of methods, Solution of simultaneous equations by Gauss-Seidel's method.

UNIT 4:

Numerical Differentiation & Integration Introduction, Numerical differentiation, Numerical integration by Trapezoidal rule, Simpson's 1/3 rule, Simpson's 3/8 rule, Boole's & Weddle's rule, Euler-Maclaurin's formula.

UNIT 5:

Solution of Ordinary Differential Equations Taylor's series method, Euler's method, Modified Euler's method, Runge-Kutta method.

Course Structure & Syllabus of B.Tech.– Petroleum Engineering

Applicable for Batch: 2021-25

Text book [TB]:

1. Sastry; Introductory Method of Numerical Analysis; PHI; 2008.
2. Balaguruswamy; Numerical Methods; TMH; 2013.

Reference books [RB]:

1. Q.S. Ahmad, S.A.Khan; Numerical and Statistical Techniques, Ane Books Pvt. Ltd; 2004.
2. Jain, Iyengar; Numerical Methods for Scientific & Engineering Computations; New Age International Publication; 2002.

Course Structure & Syllabus of B.Tech.– Petroleum Engineering

Applicable for Batch: 2021-25

1. Department offering the course	Petroleum and Energy Studies
2. Course Code	PEF361
3. Course Title	Natural Gas Engineering
4. Credits (L:T:P:C)	3:0:0:3
5. Contact Hours (L:T:P)	3:0:0
6. Prerequisites (if any)	None
7. Course Basket	

8. Course Summary

This course will introduce students about various operations in natural gas industry. Topics includes development of natural gas industry in India and worldwide, Physical and chemical properties of natural gas, Equation of state, Flow of gas in well tubing. Students will also educate on topics gas flow measurement devices, Natural gas processing and sweetening treatment, Underground storage system for collection of natural gas. Students learn about problems associate with natural gas production and their remedies.

9. Course Objectives

The students must be able to:

1. Understand physical properties of natural gas and their significance.
2. Become familiar with natural gas processing and their optimization.
3. Understand the various problems associated with natural gas production and their remedies.

10. Course Outcomes

On successful completion of the course, students will be able to achieve the following:

1. Understand development of natural gas industry and the properties of natural gas with its significance.
2. Apply different measures in the recognition of reservoir performance and understand the functioning of flowmeters.
3. Understand the natural gas processing treatments
4. Understand about the natural gas sweetening process, storage, transportation and utilization of natural gas
5. Understand about the underground storage system and problems associate with natural gas production and their remedies.

11. Curriculum Content

UNIT 1

Natural Gas Industry: Size And Direction Of Development; Properties Of Natural Gases: Typical Compositions. Equations Of State: General Cubic Equations, Specific High Accuracy Equations. Use Of Equation Of State To Find Residual Energy Properties; Thermal Properties.

UNIT 2

Flow Of Gas In Well Tubing; Pws, Pwf, Pwh Equations; Gas Flow Measurement: Orifice Meter; Turbine Meter; Principles And Performance

UNIT 3

Natural Gas Processing: Free-Liquid Removal; Low Temperature Separation; Dehydration Process: Chemical and Refrigeration System

UNIT 4

Natural Gas Sweetening: Amine Process; Sulphur Recovery; LPG; CNG Production; Natural Gas Liquefaction (NGL): Process; System; Storage; Transportation and Utilization.

Course Structure & Syllabus of B.Tech.– Petroleum Engineering

Applicable for Batch: 2021-25

UNIT 5

Underground Storage System and Production Performance; Special Problems: Natural Gas Hydrates; CBM; In-Situ Coal Gasification

Textbook(s)

1. B. Guo and A. Ghalambor, Natural Gas Engineering Handbook, Gulf Publishing Company, 2005.
2. D.L. Katz and R.L. Lee, Natural Gas Engineering, McGraw_Hill, 1990.

Reference Books

1. B. Guo, W.C. Lyons and A. Ghalambor, Petroleum Production Engineering: A Computer Assisted Approach, Elsevier, 2007.
2. T. Ahmed and P. D. McKinney, Advanced Reservoir Engineering, Elsevier, 2005.

Course Structure & Syllabus of B.Tech.– Petroleum Engineering

Applicable for Batch: 2021-25

1. Department offering the course	Petroleum and Energy Studies
2. Course Code	PEF362
3. Course Title	Petroleum Engineering System Design
4. Credits (L:T:P:C)	3:0:0:3
5. Contact Hours (L:T:P)	3:0:0
6. Prerequisites (if any)	None
7. Course Basket	

8. Course Summary

The aim of this course is to provide students to learn the basic concept of selection criteria of different design drilling rigs, advanced drilling tools, drill string design, basic casing design, 2 & 3 phase separator designs, Sucker rod pump design and gas lift design. This course covers introductions to directional drilling, Directional Well Surveying Methods, well planning, directional drilling and well trajectory calculations. The objective of the course is to provide students with a fundamental understanding of drilling procedures, directional methods, its mechanics, and design style.

9. Course Objectives

This course shall make a student competent in designing a drilling rig system including the various system employed to drill a well optimally.

10. Course Outcomes

On successful completion of the course, students have the understanding of the following:

1. The student will be able to identify different designing aspects of a drilling rig.
2. The student will be given an insight into the casing integrity aspects.
3. To be able to write different design equations for different practical situations.
4. To be able to select and design the surface separation equipment.
5. To be able to select, design, operate artificial lifts and its components.

11. Curriculum Content

UNIT 1

Selection and Design of Drilling Rig: Environmental Load, Power System, and Operating System (Hoisting, Rotary, Circulating System); Selection and Design of Drill String and casing design.

UNIT 2

Directional Well Planning; Directional Tools; Well Path Correction; Directional Well Profile Selection and Design; Directional Well Surveying Methods and Data Analysis; Well Economics; Cased and Perforated Well Performance: Total Perforation Skin.

UNIT 3

Separation System: Classifications, Working and Applications; Specification Of Optimum Separation Process; Design of 2 – Phase and 3 – Phase Horizontal and Vertical Separators, sizing of separators.

UNIT 4

Surface and Sub-surface Sucker Rod Pumping System: Working Principle, Application Considerations; Design of sucker-rod pumping production system: Theoretical Analysis of Rod Motion, Effective Plunger Stroke Length, Polished Rod Load Calculations, Counterbalance, Torque on the Gearbox, Prime Mover Pump Requirements; Dynagraph Analysis and its Applications.

Course Structure & Syllabus of B.Tech.– Petroleum Engineering

Applicable for Batch: 2021-25

UNIT 5

Gas Lift System: Classifications, Working Principle and Application Considerations; Design of gas-lift production system for continuous and intermittent gas-lift systems: Point of Gas Injection, Injection Rate, Valve Mechanics, Spacing of Valves, Injection Gas Breakthrough, Fluid Recovery per Cycle for Intermittent Gas Lift Operations and Maximum Daily Production.

Text book [TB]:

1. Michael Golan, Curtis H. Whiteson; Well Performance; Norwegian university of science and technology; 1995.
2. Kermit E. Brown and H. Dale Beggs; The Technology of Artificial Lift Methods; PennWell Company; 1977.

Reference books [RB]:

1. H. Dale Beggs; Production optimization; OGCI and Petroskills publications; 2003.
2. Adam T. Bourgoyne Jr.; Applied Drilling Engineering; SPE; 1986.

Course Structure & Syllabus of B.Tech.– Petroleum Engineering

Applicable for Batch: 2021-25

1. Department offering the course	Petroleum and Energy Studies
2. Course Code	PEF363
3. Course Title	Applied Petroleum Reservoir Engineering
4. Credits (L:T:P:C)	3:0:0:3
5. Contact Hours (L:T:P)	3:0:0
6. Prerequisites (if any)	None
7. Course Basket	DE

8. Course Summary

This course will introduce students to learn the basic concepts, tools, and techniques to analyze well performance and manage a petroleum reservoir. In this course, students will learn about reservoir drive mechanisms and the concept of a reservoir as a single tank along with a reservoir drives limitations on the use of the material balance equation. During this course students will examine the water injection and the use of fractional flow equations. Students will also learn the recovery factors of different types of reservoirs. In this course, students will review the history of reservoir engineering, define key terms, carefully introduce the material balance approach, and show how to apply it with many types of reservoirs. Students will also learn the concept of oil & gas field development plan.

9. Course Objectives

The objective of this course is make students familiar with the principles and applications material balance mathematical equation in petroleum reservoir.

10. Course Outcomes

On successful completion of the course, students have the understanding of the following:

1. Solve petroleum engineering problems by integrating different types of data used in the oil industry.
2. Identify, formulate, and solve petroleum engineering problems using real world engineering tools.
3. Recognize the main terminology, concepts, and techniques that apply to reservoir engineering founded on a theory based understanding of mathematics and the natural and physical sciences.
4. Develop a field development plan.
5. Analyse the techno-commercial aspects of field development.

11. Curriculum Content

UNIT 1

Overview of applied reservoir engineering; Material balance equation: Generalized and specific form for different drive systems, Drive-type identification, Havlena and Odeh method, Rock and fluid compressibility factor; Recovery factor estimation.

UNIT 2

Gas, gas-condensate and oil reserves: Identification from fluid composition, Performance of volumetric reservoir, Production characteristics; Reservoir drive mechanics.

UNIT 3

Performance prediction; Water influx: steady and unsteady models; Drive-Index: Reservoir pressure maintenance, Choice and system.

UNIT 4

Immiscible displacement process: Fractional flow and fractional displacement process in linear reservoir, Buckley and Leverett treatment Reservoir; Decline curve analysis.

Course Structure & Syllabus of B.Tech.– Petroleum Engineering

Applicable for Batch: 2021-25

UNIT 5

Oil and gas field development: Water flood performance, Injection-Production wells distribution patterns and characteristics, Optimum well spacing from techno economic analysis of field performance, well and field production rate estimation.

Text book [TB]:

1. Craft & Hawkins' Applied Petroleum Reservoir Engineering by Ronald E Terry and J Brandon Rogers, Third Edition, Prentice Hall, 2014.
2. J P Nguyen; Fundamentals of Exploration & Production: Oil and Gas field development techniques; Technip; 1996.

Reference books [RB]:

1. Tarek Ahmed; Reservoir Engineering Handbook; Gulf publication; 2001.
2. James.W. Amyx; Petroleum Reservoir Engineering; McGraw Hills; 1960.

Course Structure & Syllabus of B.Tech.– Petroleum Engineering

Applicable for Batch: 2021-25

1. Department offering the course	Petroleum and Energy Studies
2. Course Code	PEF441
3. Course Title	Directional Drilling
4. Credits (L:T:P:C)	3:0:0:3
5. Contact Hours (L:T:P)	3:0:0
6. Prerequisites (if any)	None
7. Course Basket	

8. Course Summary

This course will introduce students to the drilling tools and techniques that are used in deviated and horizontal wells. The directional well drilling methods and its trajectory design has been covered in this course to enable students to understand the mechanism, challenges and selection considerations while drilling in an unique sub-surface condition. This course also involves understanding the well surveying tools and surveying analysis of directional wells. The uses of MWD/LWD techniques, telemetry system, and identification along with the remedial measures for directional drilling problems have also been covered in detail in this course.

9. Course Objectives

The students should be able to:

1. Understand principles and applications of Directional drilling in petroleum operations.
2. Understand methods and analysis tools used in drilling a directional well.
3. Understand mechanisms, selection, challenges in directional drilling.

10. Course Outcomes

On successful completion of the course, students have the understanding of the following:

1. Understand applications, tools and profile designs of directional wells.
2. Understand the downhole deflection tools and their performance characteristics and select suitable bottomhole assembly.
3. Understand the objectives, selection and drilling technique for horizontal wells.
4. Understand the objectives, selection and drilling technique for slanted wells.
5. Understand the objectives and tools of MWD/LWD and telemetry system.

11. Curriculum Content

UNIT 1

Objectives; Directional Well planning, Reference systems and Coordinates, Allocation of Slots and Targets. Deflection tools; Types of Deflection Tools, Tool orientation, Directional well profiles, Well path deflection & Correction. Application of Sliding and Rotary mode for motors, Effect of torque, Drag and Weight on bit in directional wells.

UNIT 2

Positive Displacement Motors and Turbo-drills; Motor Description, Power Calculation and Applications. Effect of Build Rate on hole inclination, Weight on bit, Rotary speed, Flow rate and Drill Collar diameter. Rotary Steerable Systems; Geo-steering tool; Bit walk estimation and correction; critical buckling force in directional wells. BHA configuration for directional drilling. Selection of stabilizers and reamers for directional drilling.

UNIT 3

Horizontal well objectives and selection; Different profiles, Drilling techniques, Mud requirements & characteristics, casing and drill string requirements and completion programs. Hole cleaning and mud requirements, casing while drilling.

Course Structure & Syllabus of B.Tech.– Petroleum Engineering

Applicable for Batch: 2021-25

UNIT 4

Slant Hole Drilling; Objectives and selections, Well profiles and Applications. Down the Hole Well Surveying; Well surveying objectives, surveying methods, Surveying Analysis methods and calculations for well coordinates. Drilling problems in directional wells; (key seating, wellbore instability, differential sticking, fishing and milling) Extended reach drilling wells.

UNIT 5

Objectives of MWD/ LWD, MWD Tools, Telemetry System and Data Interpretation. Directional Drilling Problems and Remedies.

Text book [TB]:

1. H. Rabia, “Oil Well Drilling Engineering: Principles and Practices”, Graham & Trotam, Ltd.
2. Tom Inglis, “Directional Drilling”, Springer Science & Business Media

Reference books [RB]:

1. “Drilling Operations Manual”, IDT, ONGC, Dehradun.
2. Jamal J. Azar, “Drilling Engineering”, Pennwell Publications
3. Neal J. Adams, “Drilling Engineering”, PennWell Publishing Company.

Course Structure & Syllabus of B.Tech.– Petroleum Engineering

Applicable for Batch: 2021-25

1. Department offering the course	Petroleum and Energy Studies
2. Course Code	PEF442
3. Course Title	Unconventional Hydrocarbon Resources
4. Credits (L:T:P:C)	3:0:0:3
5. Contact Hours (L:T:P)	3:0:0
6. Prerequisites (if any)	None
7. Course Basket	

8. Course Summary

This course will provide an introduction to the present status of unconventional recourse, status of unconventional reservoir development. The primary focus is on coalbed methane, tight oil and gas, and even conventional reservoirs. It will also cover the resources and economic significance, geologic occurrences, controls on production rates, drilling and completion practices, reservoir management and present activity.

9. Course Objectives

The students will be able to:

1. To understand the geographic distribution of unconventional hydrocarbon resources and to understand characterization of source and reservoir rocks.

10. Course Outcomes

On successful completion of the course, students have the understanding of the following:

1. Recognize and apply the concept of continuous accumulation system.
2. Apply the concepts related to exploration and development of Shale Gas Reservoirs
3. Apply the concepts related to exploration and development of Coal Bed Methane.
4. Understand and apply the concepts related to formation of gas hydrates.
5. Understand and apply different conversion processes for the production of hydrocarbons.
6. Demonstrate awareness related to environmental issues involved in the development of non-conventional hydrocarbon resources.

11. Curriculum Content

UNIT 1:

Introduction to Unconventional Energy Resources; Occurrence; Economic Significance Of Each Technical; Economic; Political; Environmental Constraints On Development, Role of carbon capture

UNIT 2:

Introduction and present status of coal bed methane. Formation and properties of coal bed methane. Thermodynamics of coal bed methane. Drilling, completion and logging of coal bed methane wells, Hydro-fracturing of coal bed methane seam, Production, installation and surface facilities, Well operation and production equipment, Treating and disposing produced water, Testing of coal bed methane wells.

UNIT 3:

Introduction and present status of gas hydrates. Formation and properties of gas hydrates. Thermodynamics of gas hydrates, Phase behaviour of gas hydrates, Kinetics of gas hydrates. Drilling and completion of gas hydrates wells, Prevention and control of gas hydrates, Gas hydrates accumulation in porous media, Gas extraction from gas hydrates, Uses and applications of gas hydrates.

UNIT 4:

Low-Permeability (Tight) Sands: Occurrences, Resources, Reservoir Characteristics; Drilling and Completion Methods; Facilities, Reservoir Management, Limitations On Development, Present

Course Structure & Syllabus of B.Tech.– Petroleum Engineering

Applicable for Batch: 2021-25

Activity; Coal bed Gas: Occurrences; Resources; Reservoir Characteristics; Drilling And Completion Methods; Facilities, Reservoir Management, Limitations On Development, Present Activity; Water And Environmental Issues.

UNIT 5:

Shale Reservoirs (Gas and Oil): Occurrences; Resources; Reservoir Characteristics; Drilling and Completion Methods; Facilities, Reservoir Management; Limitations On Development; Water And Environmental Issues; Heavy Oil: Occurrences; Resources; Reservoir Characteristics; Drilling And Completion Methods; Limitations On Development; Environmental Issues.

Text book [TB]:

1. Rafiqul Islam; Unconventional Gas Reservoirs: Evaluation, Appraisal, and Development; Gulf Professional Publishing; 2014.
2. Coal Bed Reservoir Gas –in Place Analysis; Matt Mavor, Charles R. Nelson; Gas Research Institute.
3. A guide to Coal Bed Methane Reservoir Engineering; Jerrald L. Saulsberry; Paul S. Schafer; Gas Research Institute

Reference books [RB]:

1. James T. Bartis, Frank Camm, David S. Ortiz; Producing Liquid Fuels from Coal, Prospects and Policy Issues. NETL; 2008.
2. Carrol John; Natural Gas Hydrates: A guide for engineers; Gulf Publications; 2003.
3. Pramod Thakur, Steve Schatzel and Kashy Aminian; Coal Bed Methane: From Prospects to Pipeline; Elsevier; 2014.

Course Structure & Syllabus of B.Tech.– Petroleum Engineering

Applicable for Batch: 2021-25

1. Department offering the course	Petroleum & Energy Studies
2. Course Code	PEF443
3. Course Title	Offshore Drilling & Production Practices
4. Credits (L:T:P:C)	3:0:0:3
5. Contact Hours (L:T:P)	3:0:0
6. Prerequisites (if any)	None
7. Course Basket	

8. Course Summary

Offshore Drilling & Production Practices will cover drilling and production practices taking place in offshore along with detailed features of oceans. This course will deal with different types of drilling and production platforms and their performance in offshore environment. The production processing equipment and station keeping characteristics will be covered in the later stages of the course.

9. Course Objectives

This course will enable students to understand the performance of different types of offshore and production platforms in offshore environment along with the effect of metrological parameters. The station keeping and processing of hydrocarbons will enable students to understand the transportation and processing of hydrocarbons.

10. Course Outcomes

On successful completion of the course, students will be able to achieve the following:

- 1: A good understanding of this subject will assist in analysis of environmental loads on different platform and suitable platform selection.
- 2: The well control and rheological challenges associated with offshore.
- 3: The application of riser system and well head selection for different platforms.

11. Curriculum Content

UNIT – 1 Sea states and weather: Meteorology, oceanography & physical & biological features. Meteoceandata.wave condition. Wave- structure interaction.Sea-bed soil condition, soil strength, Soil sampling via geotechnical & geophysical tools.

UNIT – 2 Off-shore structures: Fixed platform, jack-up rig: design and operational features mobile units; semi-submersible, GBS, TLP, SPAR etc floating structures, description and installation, station keeping, mooring and Position reference systems including dynamic positioning. Offshore installation, wellhead & production platform, Central processing units.

UNIT – 3Off-shore drilling: Unique challenges in offshore drilling like reduced fracture gradient, Narrow PPF, varying drilling mud density due to temperature and pressure, gas solubility etc. Offshore well design versus onshore design.Shallow hazards. Well head and sea floor connections & connector load envelopes, common subsea connectors and gaskets; Riser & Conductor & fatigue analysis, axial and lateral loading. Off-shore well completion: Platform and subsea completion system, well control and work-over system.

UNIT – 4 Sub-sea layouts of subsea systems, Subsea equipments like horizontal and vertical trees, umbilicals, flowlines& pipelines, manifolds, templates and tie back system to Host facility and production riser systems. Use of divers and robots and ROV systems. Off-shore production: Platform oil and gas processing concepts, water and gas injection system.

Course Structure & Syllabus of B.Tech.– Petroleum Engineering

Applicable for Batch: 2021-25

UNIT – 5 Storage for oil; SPM & SBM system. FLNG systems, major components like turret, topside, hull & marine and offloading systems. FLNG challenges, ballast control and stability, space and station keeping using turret system for FPSO/ FLNG.

Text Books:

1. Offshore Structures: Design Construction and Maintenance, Mohamed A El-Reedy, Gulf professional Publication
2. Handbook of Offshore Engineering Volume I and II, Elsevier, 2006, 1213 pp. by Chakraborty S.K.
3. Dynamic Positioning Systems, Principles, Designs & Applications, Hubert Fay, Technip
4. Design for reliability in DW floating drilling operations, L. M. Harris, Petroleum Pub. Co., 1979.

Course Structure & Syllabus of B.Tech.– Petroleum Engineering

Applicable for Batch: 2021-25

1. Department offering the course	Petroleum and Energy Studies
2. Course Code	PEF444
3. Course Title	Petroleum Exploration Methods
4. Credits (L:T:P:C)	3:0:0:3
5. Contact Hours (L:T:P)	3:0:0
6. Prerequisites (if any)	None
7. Course Basket	

8. Course Summary

This course will introduce students to different exploration methods used to locate oil and gas reserves and understand the subsurface geological structures. Basic techniques utilised in geological and geophysical analyses of the subsurface are discussed. The interpretation of the data to produce maps or models of the reflecting interfaces is covered, and data acquisition and processing required to produce the seismic images.

9. Course Objectives

The students should be able to:

1. Understand Geophysical and Geochemical methods for exploitation of Oil and Gas.
2. Understand different anomaly and geological structures.
3. Understand various fundamentals of seismic and electrical methods.

10. Course Outcomes

On successful completion of the course, students have the understanding of the following:

1. Understand students to delineate the subsurface features for exploration of oil and gas.
2. The Geochemical methods will assist in hydrocarbon correlation, maturity and classification of reserves.
3. The good concepts of geophysics will assist students in building better concepts of well logging.
4. The sound knowledge of this course will make student competent for better understanding of petroleum operation.
5. Learn about the prospect of oil and gas in India and abroad.

11. Curriculum Content

Unit 1:

Surface Indication of oil/gas accumulation: Accumulation Parameters, Regional and local structures. Time of generation vis-à-vis accumulation, Statistical analysis and spatial variations; grid survey model and economics; Magnetic survey: survey instruments Geo-magnetic anomalies, field methods, Data correction and reduction. Anomaly interpretation. Response for different type of geological structures.

Unit 2:

Geochemical methods of prospecting: micro seepage detection, Direct and Indirect methods of geochemical analysis; Radiometric, Microbiological, Helium method, Ph/Eh method, Soil-chemical survey, source-rock characterization; Hydro-geochemistry as exploration tool. Plate tectonics and hydrocarbon accumulation.

Gravity method: Units, Measuring instruments, Gravity anomaly, Data correction and reduction. Free-air and Bouguer Anomalies. Anomaly interpretation and Application.

Unit 3:

Seismic methods: Type, Methodology of Refraction profiling. Field survey arrangements. Recoding instruments. Data correction, Special shooting methods: Fan and broadside. Data interpretation and application in identification of structures. Reflection Seismograph and Seismogram relative Advantage over refractive survey. Common Depth Point Profiling and stacks time correction. Well seismic methods. Vertical seismic profiling. Interpretation. 3D data acquisition and interpretation,

Course Structure & Syllabus of B.Tech.– Petroleum Engineering

Applicable for Batch: 2021-25

application of reflection survey.

Unit 4:

Geological exploration processes: Sequence of operation. Field development: Prognostication of reserve; Geophysical Exploration Methods and their significance.

Unit- 5:

Electrical methods – Introduction to Resistivity method, Resistivity surveys, Equipment for measurement, electrode layout and field procedure. Data acquisition and interpretation.

Textbooks:

1. John Milsom; Field Geophysics; Wiley; 2007.
2. Allen P A and J R Allen; Basin Analysis: Principles and Applications; Wiley Blackwell; 2005.

Reference Books:

1. Tedesco S. A.; Sur face Geochemistry in Petroleum Exploration; Chapman and Hall Publishing,1993.
2. William Murray Telford, W. M. Telford, L. P. Geldart, Robert E. Sheriff ; Applied Geophysics; 1990.
3. Philip Kearey, Michael Brooks, Ian Hills; An Introduction to Geophysical Exploration; Wiley; 2013.

Course Structure & Syllabus of B.Tech.– Petroleum Engineering

Applicable for Batch: 2021-25

1. Department offering the course	Petroleum and Energy Studies
2. Course Code	PEF445
3. Course Title	Oil and Gas Field Development
4. Credits (L:T:P:C)	3:0:0:3
5. Contact Hours (L:T:P)	3:0:0
6. Prerequisites (if any)	None
7. Course Basket	

8. Course Summary

This course will introduce students to the oil and gas well production system including the equipment that are being used and the diverse operations being carried out. The surface and sub-surface operations should be designed such that we produce optimally from the reservoir. The Nodal analysis at every node in the production system is done to optimize the well production. The selection and application of suitable artificial lift techniques will be discussed in this course for the depleted reservoirs along with various problems that are encountered during the operation and their remedial measures.

9. Course Objectives

The students should be able to:

1. Understand about the basic subsurface and surface production operations and equipment.
2. Understand Reservoir and well deliverability to optimize the production.
3. Understand the artificial lift methods to improve oil recovery from depleted reservoirs.

10. Course Outcomes

On successful completion of the course, students have the understanding of the following:

1. Understand production equipment and operations in oil and gas industry
2. Design the production system to optimize the oil and gas recovery
3. Understand the SRP working and application considerations
4. Understand the Gas Lift working and application considerations
5. Select the best fit artificial lift for candidate well

11. Curriculum Content

Unit 1:

The Field Life Cycle: Gaining Access, Exploration Phase, Appraisal Phase, Development Phase, Production Phase, Decommissioning.

Exploration: Hydrocarbon Accumulations, Exploration methods & techniques.

Drilling Engineering Brief overview: Well Planning, Rig types & Rig Selection, Drilling systems and Equipment, Site Preparation, Costs & Contracts.

Unit 2:

Reservoir Description: Data Gathering, Data Interpretation.

Volumetric and Probabilistic Method of Reserve Estimation.

Field Appraisal: Importance of Appraisal, Identifying and quantifying sources of Uncertainty, Cost benefit calculations for Appraisal.

Reservoir Dynamic Behavior: Fluid Flow studies, PVT data, Drive Mechanisms. Gas Reservoirs: Difference between oil and gas field development, Influence of Contacts; movement of GWC during production, Pressure response, Fluid displacement in the Reservoir, Estimation of Reserves, Reservoir Simulation, Estimating the Recovery Factor, Estimating the Production Profile.

Unit 3:

Well Dynamic Behavior: Estimating the number of Development Wells, Fluid flow near the wellbore, Horizontal Wells, Production Testing & Bottom Hole Pressure Testing, Tubing Performance, Well Completions, Intelligent Wells, Artificial Lift.

Surface Facilities: Oil and Gas processing, Production Support systems, Land based & offshore

Course Structure & Syllabus of B.Tech.– Petroleum Engineering

Applicable for Batch: 2021-25

production facilities, Control Systems.

Production Operations & Maintenance: Production input to the FDP, manning, logistics, Communications, Cost Control, Maintenance Strategy & costs.

Unit 4:

Project & Contract Management: Phasing & Organisation, Planning & Control, Cost Estimation & Budgets, Types of Contracts.

Petroleum Economics: Basic principles of Development Economics, Project Cash flow, Revenue & expenditure items, CAPEX-OPEX, Host Government take, Capital Allowances, Economic Indicators, Project Screening, Sensitivity Analysis.

Risk Analysis: Definition, Risk Matrix, Stakeholder Analysis, Risk to Capital Investment.

Unit- 5:

Managing the Producing Field: Subsurface, surface facilities, Internal & External factors.

Managing Decline: Infill Drilling, Work over Activity, Enhanced Oil Recovery, Extended Reach Development.

Decommissioning: Legislation, Decommissioning Methods.

Textbook(s)

1. Thomas O. Allen & Alan P. Roberts ; Production Operations Vol.- 1 & Vol. 2; Oil and Gas consultants international; 1982.
2. B. C. Craft, M. Hawkins; Applied Petroleum Reservoir Engineering; Prentice Hall; 2014.

Reference Books

1. Ken Arnold & Maurice Stewart; Surface production Operation Vol.-1 & Vol. 2; Gulf publishing compony; 1989.
2. Michael J. Economides, A. Daniel Hill and Christine Ehlig- Economides; Petroleum Production Systems; Prentice hall Petroleum Engineering Series; 1994.

Course Structure & Syllabus of B.Tech.– Petroleum Engineering

Applicable for Batch: 2021-25

1. Department offering the course	Petroleum and Energy Studies
2. Course Code	PEF446
3. Course Title	Oil and Gas Transportation System
4. Credits (L:T:P:C)	3:0:0:3
5. Contact Hours (L:T:P)	3:0:0
6. Prerequisites (if any)	None
7. Course Basket	

8. Course Summary

This course will introduce students to various oil and gas transportation methods, pipeline route selection, and equipment's used in transportation. In this course, students unable to understand design of storage vessels, pipeline route selection and construction process. This course also covered hydraulic calculation, flow measurement devices, Types of measurement and controlling devices, Oil and Gas Transportation control System, Corrosion prevention and protection methods, Oil and Gas pipeline network.

9. Course Objectives

The students should be able to:

4. Understand different modes of crude oil and petroleum products transportation and their safety features
5. Understand the pipeline route selection and pipeline construction process
6. Understand the hydraulic calculation, Pump and compressor design, Pipeline control system, Pipeline branching, Pipeline corrosion control methods

10. Course Outcomes

1. A good knowledge of this course will enable student to design tankers and pipeline for transportation of oil and gas.
2. To enable students in pipeline route selection and in pipeline construction process
3. Students understand importance of hydraulic calculation, instrumentation and control system in pipeline design system
4. Students become familiar with causes of pipeline corrosion, Pipeline corrosion protection methods, Pipeline cleaning and inspection system
5. Students enable to understand Pipeline branching & distribution control system, and functioning of stinger & riser, Underwater Welding

11. Curriculum Content

UNIT 1

Road and Rail Transport of Crude Oil & Product; Tanker Design, Safety Features, Oceanic Transport of Oil and Liquefied Natural gas; Design of Ocean Going Tankers and Safety Features

UNIT 2

Pipe Line Transport of Oil and Gas; Route Selection, Pipe line Construction Process and Equipment: Trenching, aligning, Connecting Pipes, Corrosion Protection, Lowering & Back filling.

UNIT 3

Flow of oil and Gas through Pipelines; Pressure Drop Calculation in Series and Parallel, Types, Sizing and location of Pumps and Compressor, Instrumentation and Control.

UNIT 4

Flow Measurement and Control Arrangement; Corrosion in Pipelines, Types, Chemical and Electrochemical process; Coating, Cathodic protection principle and design. Pigs and it's application for pipeline cleaning and maintenance.

Course Structure & Syllabus of B.Tech.– Petroleum Engineering

Applicable for Batch: 2021-25

UNIT 5

Pipe line branching; Gas distribution control, Offshore pipe line; Sag and overbend; stinger and riser, under-water welding

Text book [TB]:

1. Pipeline engineering by Henry Liu, Lewis Publishers Washington, D.C.

Reference books [RB]:

1. Piping and pipeline engineering, George A. Antaki, Marcel Dekker Inc. New York.
2. Fundamentals of pipeline engineering by J. Vincent Genod, Technip Editions

Course Structure & Syllabus of B.Tech.– Petroleum Engineering

Applicable for Batch: 2021-25

1. Department offering the course	Petroleum and Energy Studies
2. Course Code	PEF447
3. Course Title	IoT and Cloud Computing in Petroleum Industry
4. Credits (L:T:P:C)	2:0:1:3
5. Contact Hours (L:T:P)	2:0:2
6. Prerequisites (if any)	None
7. Course Basket	DE

8. Course Summary

In this course students will be introduced to fundamental and architectural concepts of IoT systems, various kinds of communication using system-on-chip devices, and building IoT prototypes. Students will learn how to create an end-to-end system by connecting to IoT cloud, perform IoT Analytics and understand cloud security.

9. Course Objectives

The objective of this course is to provide both conceptual and hands-on knowledge to students for IoT systems. Students will learn how to build and use end-to-end IoT systems, perform analytics on the data collected and understand security aspects of an IoT system.

10. Course Outcomes

On successful completion of the course, students have the understanding of the following:

1. Understand fundamental concepts and building blocks of an IoT system.
2. Understand and implement IoT prototypes using system-on-chip devices.
3. Understand and develop end-to-end systems by syncing with Cloud.
4. Understand analytics and visualization of an IoT system.
5. Understand security aspects of an IoT system.

11. Curriculum

Content UNIT 1:

Introduction, IoT Architecture, Sensing, Communication and Actuation.

UNIT 2:

Hardware and Software setup, GPIO pins setup and programming.

UNIT 3:

Serial Communication in IoT, SPI and I2C in IoT.

UNIT 4:

Data transmission in Cloud, IoT Analytics and Visualization.

UNIT 5:

IoT Security, IoT Project execution and demonstration

Course Structure & Syllabus of B.Tech.– Petroleum Engineering

Applicable for Batch: 2021-25

List of Experiments:

1. **Lab 1 and 2:** Develop prototype using Arduino Uno,
2. **Lab 3, 4, 5:** Setup and Develop prototype using Raspberry Pi and environmental sensors
3. **Lab 6, 7, 8, 9:** Temperature, Humidity (DHT22), Movement detection and distance measurement using RPI, Detect movement using an HC-SR501 passive infrared (PIR) motion detector, and HC-SR04 ultrasonic ranging module.
4. **Lab 10-11:** Cloud interfacing with SOC devices, sample data upload for visualization and Analysis.

Text book [TB]:

1. Cuno Pfister; Getting Started with the Internet of Things: Connecting Sensors and Microcontrollers to the Cloud; 1st edition; Maker Media, Inc; 2011.

Reference books [RB]:

1. Samuel Greengard; The Internet of Things; The MIT Press; 2015.

Course Structure & Syllabus of B.Tech.– Petroleum Engineering

Applicable for Batch: 2021-25

1. Department offering the course	Petroleum and Energy Studies
2. Course Code	PEF448
3. Course Title	Cyber Security in Petroleum Industry
4. Credits (L:T:P:C)	3:0:0:3
5. Contact Hours (L:T:P)	3:0:0
6. Prerequisites (if any)	None
7. Course Basket	SEC

8. Course Summary

This course aims to give an outline of cyber security. The course will equip students with a vibrant view of the existing cyber security landscape considering not only technical measures and defences, but also the other theme areas including legal, management, crime, risk, social and human factors.

9. Course Objectives

The objective of this course is to:

- To understand the crucial necessity of cyber security in computer systems, networks and enlighten numerous threat scenarios.
- To understand the well-known cyber-attack events, clarify the attack scenarios, and enlighten mitigation techniques.
- To understand the variance between Systems Cyber Security, Network Cyber Security, and cryptography, crypto-protocols etc.
- To analyses the cyber threats to critical structures.

10. Course Outcomes

On successful completion of the course, students have the understanding of the following:

1. The cyber threat landscape, both in terms of recent developing issues and those issues which persist over time.
2. The roles and effects of governments, commercial and other organisations, citizens and criminals in cyber security affairs.
3. General values and policies that can be functional to systems to make them more vigorous to attack.
4. Key factors in cyber security from different corrective views including computer science, management.
5. Understand law, criminology, and social sciences involved in cyber security.

11. Curriculum

Content UNIT 1:

Overview of Cyber Security, Cyber Threats & Crime, Cyber Espionage, Internet Governance, Challenges and Constraints, necessity for a Comprehensive Cyber Security Policy, necessity for a Nodal Authority, necessity for an International convention on Cyberspace.

UNIT 2:

Overview, vulnerabilities in software, Intrusion, Physical Theft, Abuse of Privileges, Malware infection, System administration, Complex Network Architectures, Open Access to

Course Structure & Syllabus of B.Tech.– Petroleum Engineering

Applicable for Batch: 2021-25

Organizational Data, Weak Authentication, Unprotected Broadband communications, Poor Cyber Security Awareness.

UNIT 3:

Security Practices: Security Management, Security Policy, Risk Management, Information Classification Process, Security Procedures and Guidelines, Business Continuity and Disaster Recovery.

Security Safeguards: Overview, Access control, Audit, Authentication, Biometrics, Cryptography, Deception, Denial of Service Filters, Ethical Hacking, Firewalls, Intrusion Detection Systems, Response, Scanning, Anti-Malware software.

UNIT 4:

Intrusion detection and Prevention Techniques, Basic security for HTTP Applications and Services, Basic Security for SOAP Services, Identity Management and Web Services, Authorization Patterns, Security Considerations, Challenges, Network based Intrusion detection & Prevention Systems.

UNIT 5:

Security Laws & Standards: Cyber Security Regulations, Roles of International Law, the state and Private Sector in Cyberspace, Cyber Security Standards. The INDIAN Cyberspace, National Cyber Security Policy.

Cyber Forensic: Overview, Handling Preliminary Investigations, Controlling an Investigation.

Text book [TB]:

1. Micki Krause, Harold F. Tipton, "Handbook of Information Security Management", Vol 1-3, CRC Press LLC, 2004.

Reference books [RB]:

1. Bill Nelson, "Computer Forensics and Investigations", Cengage Learning, India Edition, 2016.
2. Matt Bishop "Computer Security Art and Science", Pearson/PHI, 2002.

Course Structure & Syllabus of B.Tech.– Petroleum Engineering

Applicable for Batch: 2021-25

1. Department offering the course	Petroleum and Energy Studies
2. Course Code	PEF381
3. Course Title	Carbon Capture and Sequestration
4. Credits (L:T:P:C)	3:0:0:3
5. Contact Hours (L:T:P)	3:0:0
6. Prerequisites (if any)	None
7. Course Basket	

8. Course Summary

The course provides information about the students to learn the basic concept and Applications of Carbon capture and storage process. In this course, students will learn about carbon capture techniques and the concept of the contribution of fossil fuel to climate change. During this course students will examine the Co₂ emission and Carbon dioxide recycling.

9. Course Objectives

The objective of this course is make students familiar with the principles and applications of carbon capture and storage capture techniques and role of CCS.

10. Course Outcomes

On successful completion of the course, students have the understanding of the following:

1. To acquaint the students substantially to the objectives and necessity of Carbon Sequestration and capture.
2. To introduce the contribution of fossil fuel to climate change.
3. To understand the concept of emission and recycling of CO₂.
4. To introduce the candidates to the concept of underground storage and other Carbon Capture and sequestration concepts.
5. To understand the implementation of CCS technology and IPCC.

11. Curriculum Content

UNIT – 1

Introduction: Scope, Objectives and Necessity of CCS

UNIT – 2

The contribution of fossil fuels emission to Climate change and global warming. Concept of Carbon Credit and carbon footprint.

UNIT – 3

Carbon capture techniques: Carbon-di-oxide emission, Scrubbing of CO₂, Carbon dioxide recycling

UNIT – 4

Carbon dioxide sequestration: Underground storage, Potential for Geologic Storage, Application in Oil and gas industry, Carbon di oxide flooding projects, Methane recovery projects.

UNIT – 5

Strategy for implementing CCS technology: Modelling of Cost and Performance of CCS Plants. Role and function of IPCC

Text book [TB]:

1. Carbon Capture; Jennifer Wilcox; Springer
2. Capturing Carbon – The new weapon in the War Against Climate Change; Mills, Robin M.; Columbia University Press.

Reference books [RB]:

1. Carbon Dioxide Capture and Storage: Cambridge University Press, New York
2. Carbon Capture and Storage: Physical, Chemical, and Biological Methods: ASCE Book Series

Course Structure & Syllabus of B.Tech.– Petroleum Engineering

Applicable for Batch: 2021-25

1. Department offering the course	Petroleum and Energy Studies
2. Course Code	PEF491
3. Course Title	Polymer Technology
4. Credits (L:T:P:C)	3:0:0:3
5. Contact Hours (L:T:P)	3:0:0
6. Prerequisites (if any)	None
7. Course Basket	

8. Course Summary

The main theme of the course on Science and Technology of Polymers is to focus understanding of science and technology of polymer synthesis and its characterization. Knowledge on solid state structure and properties of polymers will enable their proper selection for applications in domestic as well as industrial appliances.

9. Course Objectives

The objective of this course is to introduce the basic concept of polymer, Polymer fabrication processes and methods of characterization and identification of polymers are presented. Experiments in polymerization, processing, and property evaluation of polymers.

10. Course Outcomes

1. Student should be able to understand the basic concept of monomer, polymer and repeating units and their properties
2. Student should be able to understand the basic concepts of degree of polymerisation
3. Student should be able to understand in detail about the chemistry of polymers and the possible chemical modification
4. Student should be able to understand the physical and chemical characterization of raw materials
5. Ability to understand the applications of various polymers

11. Curriculum Content

Unit 1: Introduction

Basic concepts on polymers. Polymer raw materials. Polymerization principles and processes (step, chain and other polymerizations, polymer kinetics).

Unit 2: Polymerization Technoque

The synthesis of high polymers Step-growth polymerization. Chain growth polymerization. Polymerization techniques, Reactions of synthetic polymers, Polymer manufacture (unit operations, polymer reactors, polymer isolation, handling and storage). Polymer structure and property. Polymer characterization. Polymer modification.

Unit 3: Chemical Modification of Polymer

Multicomponent polymeric materials (polymer miscibility, polymer blends and alloys, filled plastics, polymer composites).

Unit 4: Polymer additives and characterization

Polymer compounding and fabrication (polymer additives, Compounding processes, fabrication techniques, post fabrication operations). Polymer testing (sample preparation, testing standards and methods, analysis of polymer and additives).

Unit- 5: Polymer Applications

Polymer applications: Biodegradable polymers, biomedical polymers, conducting polymers. Problems with polymers (thermo oxidative degradation, fire hazards, toxicity, effluent disposal, feedstock scarcity).

Course Structure & Syllabus of B.Tech.– Petroleum Engineering

Applicable for Batch: 2021-25

Textbook(s)

1. Fred W. Billmeyer, Jr., Textbook of Polymer Science, 3rd Edition, John Wiley & Sons, Singapore, 1994.
2. George Odian, Principles of Polymerization, Second Edition, John Wiley & Sons, New York, 1981.
3. Charles E. Carraher, Jr., Seymour/Carraher's Polymer Chemistry, 5th Edition, Marcel Dekker, Inc., New York, 2000.
4. Premamoy Ghosh, Polymer Science and Technology, Second Edition, Tata McGraw-Hill Publishing Company Ltd., New Delhi, 2002.

Reference Books

1. John Brydson, Plastic Materials, Seventh Edition, Butterworth-Heinemann, An Imprint of Elsevier, New Delhi, 1999.
2. Werner Hofmann, Rubber Technology Handbook, Hanser Publishers, Munich, 1989.
3. Martin Alexander, Biodegradation and Bioremediation, second Edition, Academic Press, London, 1999.

Course Structure & Syllabus of B.Tech.– Petroleum Engineering

Applicable for Batch: 2021-25

1. Department offering the course	Petroleum and Energy Studies
2. Course Code	PEF492
3. Course Title	Health, Safety and Environment in Industry
4. Credits (L:T:P:C)	3:0:0:3
5. Contact Hours (L:T:P)	3:0:0
6. Prerequisites (if any)	None
7. Course Basket	

8. Course Summary

The course will introduce students to the need and scope of health, safety and environment in industry. The students will learn about the sources and causes of pollution, effects of the pollutants on livings and environment, and the safety and remedial measures that should be adopted to reduce the pollution.

9. Course Objectives

The students should be able to:

1. Understand the sources of pollutions.
2. Understand the effects of pollutions on health and environment.
3. Understand the remedial measures and safety precautions associated with each source of pollution.

10. Course Outcomes

On successful completion of the course, students have the understanding of the following:

1. Understand the scope of HSE in industry.
2. Understand the sources, effects and remedies of air pollution.
3. Understand the sources, effects and remedies of water pollution.
4. Understand the sources, effects and remedies of liquid and solid wastes.
5. Understand the sources, effects and remedies of noise pollution.

11. Curriculum Content

UNIT 1

Introduction: Man And Environment: Overview (Socio-Economic Structure & Occupational Exposures); Scope Of Environmental Engineering; Pollution Problems Due To Urbanization & Industrialization.

UNIT 2

Air Pollution : Causes Of Air Pollution; Types & Sources Of Air Pollutants; Climatic & Meteorological Effect On Air Pollution Concentration; Formation Of Smog And Fumigation; Analysis Of Air Pollutants Collection Of Gaseous Air Pollutants; Collection Of Particulate Pollutants; Analysis Of Air Pollutants Like : Sulphur Dioxide, Nitrogen Oxide, Carbon Monoxide, Oxidants & Ozone; Hydrocarbons; Particulate Matter; Control Of Particulate Emission- Control Of Gaseous Emission; Flue Gas Treatment Methods : Stacks Gravitational And Inertial Separation; Settling Chambers; Dynamic Separators; Cyclone; Filtration; Liquid Scrubbing; Spray Chambers; Packed Towers; Orifice And Venturi Scrubbers; Electrostatic Precipitators.

UNIT 3

Water Pollution & Its Control - Origin Of Waste Water – Types Of Water Pollutants And Their Effects ; Adverse Effects On: Human Health & Environment; Aquatic Life; Animal Life; Plant Life; Water Pollution Measurement Techniques; Water Pollution Control Equipments & Instruments; Indian Standards For Water Pollution Control.

Course Structure & Syllabus of B.Tech.– Petroleum Engineering

Applicable for Batch: 2021-25

UNIT 4

Liquid & Solid Wastes – Domestic & Industrial Wastes; Pesticides; Toxic: Inorganic & Organic Pollutants; Soil Deterioration; Ground Water Pollution; Concentration Of Infecting Agents In Soil; Solid Waste Disposal; Dumping Domestic & Industrial Solid Wastes; Advantages & Disadvantages; Incineration- Advantages & Disadvantages – Sanitary Land Field: Advantages & Disadvantages; Management Of Careful & Sanitary Disposal Of Solid Wastes.

UNIT 5

Noise Pollution & Control: Intensity; Duration; Types Of Industrial Noise; Ill Effects Of Noise; Noise Measuring & Control; Permissible Noise Limits.

Text book [TB]:

1. J. Turk & A. Turk, “Environmental Science Environmental Pollution”.

Reference books [RB]:

1. Odum, “Fundamental of Ecology.

Course Structure & Syllabus of B.Tech.– Petroleum Engineering

Applicable for Batch: 2021-25

1. Department offering the course	Humanities & Liberal Arts
2. Course Code	LAF281
3. Course Title	Introduction to Psychology
4. Credits (L:T:P:C)	3:0:0:3
5. Contact Hours (L:T:P)	3:0:0
6. Prerequisites (if any)	NIL
7. Course Basket	Humanities & Liberal Arts

8. Course Summary

This course will highlight the most interesting scientific findings and insights of psychology, discussing the implications of those for our understanding of the human mind and human behaviour. We will explore some of the cognitive abilities including memory, learning, attention, perception and consciousness. We will examine the trajectory of growth of psychological perspectives. By the end of this course you will have gained a fascinating understanding and appreciation of who you are and how you work and relate with others. And I can guarantee you that you'll learn things that you'll be telling your friends and family about, things that will fundamentally change the way you think of yourself and others.

9. Course Objectives

The purpose of this course provides coverage for the broad range of learning outcomes that may be taught in introductory psychology courses. With the goal of supporting faculty in the selection of content for their courses, we have organized this course around the 5 pillars, or domains, of psychology as recently recommended by the American Psychological Association: biological pillar, cognitive pillar, developmental pillar, and social and personality pillar, mental and physical health pillar.

10. Course Outcomes

On successful completion of the course, students will be able to achieve the following:

1. Identify the various approaches, fields, and subfields of psychology along with their major concepts and important figures
2. Describe the strengths and weaknesses of descriptive, experimental, and correlational research
3. Explain how nature, nurture, and epigenetics influence personality and behaviour
4. Explain the physical, cognitive, and emotional development that occurs from infancy through childhood
5. Recognize aspects of social psychology, including the fundamental attribution error, biases, social roles, and social norms, in your daily life.

11. Curriculum Content

Unit 1 Introduction

Definition, Scope, Perspectives: biological, psychoanalytic, behavioural, cognitive, humanistic, Methods: experiment, case study.

Unit 2 Cognitive Processes

Course Structure & Syllabus of B.Tech.– Petroleum Engineering

Applicable for Batch: 2021-25

Perception: Meaning, laws of perceptual organization, identifying perceptual errors; Techniques for improving our behaviors: Classical conditioning, Reinforcement theory & Modeling; Creative Thinking & Problem-Solving

Unit 3 Motivation and Emotion

Motivation: definition, self-motivation through goal setting, self-regulation, motivating employees, improving confidence; Emotion: definition, types, emotion and health, assessing emotional intelligence, body language.

Unit-4 Human abilities

Self & Personality: definition, approaches for assessment, exploration through JOHARI Window; Understanding intelligence; Stress: meaning & coping; Conflict: definition & resolution;

TEXT BOOKS

1. Baron, R.A. and Misra, G., Psychology (Indian Subcontinent Edition). Person Education Ltd. (2014)
2. Chadha, N.K. & Seth, S., The Psychological Realm: An Introduction. Pinnacle Learning, New Delhi. (2014)

REFERENCE BOOKS

1. Ciccarelli, S.K. & Meyer, G.E., Psychology (South Asian Edition). New Delhi: Tata Mc Graw Hill. (2008).\
2. Glassman, W.F., Approaches to Psychology (3rd Ed.) Buckingham: Open University Press. (2000).
3. Passer, M.W., Smith, R.E., Holt, N. and Bremner, A., Psychology: The Science of Mind and Behaviour, McGraw-Hill Education, UK. (2008).

12. Teaching and Learning Strategy

All materials (PPTs, Assignments, Seminars, etc.) will be uploaded in Moodle.

Course Structure & Syllabus of B.Tech.– Petroleum Engineering

Applicable for Batch: 2021-25

1. Department offering the course	Humanities & Liberal Arts
2. Course Code	LAF282
3. Course Title	Human Values
4. Credits (L:T:P:C)	3:0:0:3
5. Contact Hours (L:T:P)	3:0:0
6. Prerequisites (if any)	NIL
7. Course Basket	Humanities & Liberal Arts

8. Course Summary

This course will introduce students to the nature of the individual and the relationship between the self and the community. It includes Principles of Interdependence between individuals and society and role of material values in promoting human well-being. It also includes psychological and spiritual values through topics like Humanistic Psychology, religion, concept of Dharma and Spirituality morality, Professional values and developing an open and balanced mind.

9. Course Objectives

To inculcate the skills of ethical decision making and then to apply these skills to the real and current challenges of the Engineering profession. The main objective of the course is to enable the students to understand the need and importance of value-education and education for Human Rights. It also aims to develop their inter personal and leadership skills and empower them to develop into evolved human beings.

10. Course Outcomes

On successful completion of the course, students will be able to achieve the following:

1. Students will become more sensitive to their surroundings including both people and nature, with commitment towards what they believe in (human values).
2. Be able to understand how universal values can be uncovered by different means, including scientific investigation, historical research, or public debate and deliberation (what some philosophers call a dialectic method).
3. They will become more aware of their self and their relationships and have better reflective and discerning ability.
4. Be able to understand and discuss the idea of moral relativism and the challenges it poses to universal values.

11. Curriculum Content

Unit 1 INTRODUCTION

Nature of Value-Crisis in the contemporary Indian society, Meaning, Nature & Types of Values; Sources of Value Formation, Foundational Human Values – Integrity, Freedom, Creativity, Morals, Love and Wisdom, Case Studies Case Studies on the above aspects

Unit 2 SOCIETAL VALUES & MATERIAL VALUES

Course Structure & Syllabus of B.Tech.– Petroleum Engineering

Applicable for Batch: 2021-25

Definition of Society, Units of Society, and Social Consciousness. Concepts & Principles of Interdependence, Conceptualizing ‘Good Society’ and ‘Social Goods’ and Corporate Social Responsibility, Role of Material Values in promoting Human Well-being. Role of Science and Technology; Problems of Material Development, Case Studies Case Studies on the above aspects

Unit 3 PSYCHOLOGICAL & SPIRITUAL VALUES

Humanistic Psychology; Concept of Intelligence, Emotional Intelligence & Mental health; Cognitive Dissonance & Ego Defense, Maslow’s Hierarchy of Human Need; Characteristics of ‘Self-Actualizing’ persons; Understanding Common Religion & Concept of Dharma and Spirituality; Case Studies Case Studies on the above aspects

Unit 4 PSYCHOLOGICAL & SPIRITUAL VALUES

Bases for moral Judgments: Customary Morality, Religious Morality, Reflective Morality. Concept of Professional values: Competence , Confidence , Devotion to Duty, Efficiency , Accountability , Respect for learning / Learned , Willingness to Learn, Open and Balanced mind; Team spirit ; Willingness for Discussion, Aims, Effort , Avoidance of Procrastination and Slothfulness, Alertness, IEEE; Case Studies Case Studies on the above aspects

Textbook(s)

1. Human Values - Prof. A.N.Tripathi New Age International, 2009

Reference Books

1. Human Values and Professional Ethics - Jayshree, Suresh and B.S. Raghwan , S. Chand Publication, 2011-12

12. Teaching and Learning Strategy

All materials (ppts, assignments, labs, etc.) will be uploaded in Moodle. Refer to your course in Moodle for details.

Course Structure & Syllabus of B.Tech.– Petroleum Engineering

Applicable for Batch: 2021-25

1. Department offering the course	Humanities & Liberal Arts
2. Course Code	LAF283
3. Course Title	Literature, Language & Society
4. Credits (L:T:P:C)	3:0:0:3
5. Contact Hours (L:T:P)	3:0:0
6. Prerequisites (if any)	NIL
7. Course Basket	Humanities & Liberal Arts

8. Course Summary

This course will introduce students about the literature, language & society. It also includes the overview of aspects of literature and language with its impact on the society. The course explores the dimensions of literature, its nature and its functions with its approaches to the study of society. It explores the role of language and literature in the society. The course will through study of text, also analyse the practical aspect of it.

9. Course Objectives

The main objective of the course is to focus is on the interaction between literature & Society, and Literature and visual culture. This course is also about how Literature reacts to major changes in society. This course offers the students to experience different dimension of literature and language.

10 Course Outcomes

On successful completion of the course, students will be able to achieve the following:

1. Students will read critically from a variety of genres, specifically poetry, drama, non-fiction, and fiction.
2. Students will read literature more carefully and meaningfully, practicing close-reading skills.
3. Students will understand the relation between historical and cultural contexts.
4. The students will develop a critical understanding of how literature can both uphold and resist existing structures of power.

11. Curriculum Content

Unit 1:

Nature and Functions of Literature, Literature and Society with special reference to Indian Literature and Indian Society, Literary Forms, Poetry, Drama, Fiction, Essay, Autobiography

Unit 2:

Approaches to the Study of Literature, Reader response to the study of Literature, Interpretation, Appreciation, Evaluation, Special problems in understanding Modern Literature.

Unit 3:

Social dimension of language. problems of multilingual communities, dominance and conflict, shift and attrition, language and the state, language and nation, Indian multilingualism, language variation, language and identity, linguistic prejudice and inequality, standardization, linguistic determinism, critical discourse analysis, and methodological issues.

Course Structure & Syllabus of B.Tech.– Petroleum Engineering

Applicable for Batch: 2021-25

Unit 4:

Jerome K Jerome: Three Men on a Bummel (selection), Martin Amis: Last Days of Muhammad Atta, Li Ho: A Girl Comb her hair, R.K. Narayan: Malgudi Days (selection)

Textbook(s)

1. Jerome K Jerome: Three Men on a Bummel (selection), Arrow smith Publications.
2. R.K. Narayan: Malgudi Days (selection), Indian Thought Publications.

Reference Books

1. Martin Montgomery, An Introduction to Language and Society (Studies in Culture and Communication) Routledge; 2 edition (December 22, 1995).
2. Robe Pope, An Introduction to Language Literature and Culture. Routledge, 2005.

1. Teaching and Learning Strategy

All materials (ppts, assignments, labs, etc.) will be uploaded in Moodle. Refer to your course in Moodle for details.

Course Structure & Syllabus of B.Tech.– Petroleum Engineering

Applicable for Batch: 2021-25

1. Department offering the course	Humanities & Liberal Arts
2. Course Code	LAF284
3. Course Title	Principles of Management
4. Credits (L:T:P:C)	3:0:0:3
5. Contact Hours (L:T:P)	3:0:0
6. Prerequisites (if any)	NIL
7. Course Basket	Humanities & Liberal Arts

8. Course Summary

This course will introduce students about the basic Principles needed for management. It also includes case studies where a student can get idea about the actual working of the management field. Topics include Overview of Management, Management Information, and Planning Approach to Organizational Analysis, Motivation and Productivity.

9 Course Objectives

The objective of this course is to familiarize B.Tech. Students with the roles, responsibilities, and skills required of modern managers. This course will be present the concepts of management as it applies to current thinking in the workplace.

10. Course Outcomes

On successful completion of the course, students will be able to achieve the following:

- To present the topics in management, management theories, while at the same time focusing on practical applications in the real world especially for engineers.
- Evaluate the global context for taking managerial actions of planning, organizing and controlling.
- Assess global situation, including opportunities and threats that will impact management of an organization.
- Integrate management principles into management practices.

11. Curriculum Content

Unit 1 Overview of management

Definition-Management-Role of managers-Organization and the internal and environmental factors – Trends and Challenges of Management in India.

Directing – delegation –span of control– communication, Controlling

Unit 2 Management Information

Introduction to functional areas of management, Operations management, Human resources management, Marketing management, Financial management

Course Structure & Syllabus of B.Tech.– Petroleum Engineering

Applicable for Batch: 2021-25

Unit 3 Planning Approach to Organizational Analysis

Design of organization structure; job design and enrichment; job evaluation and merit rating

Unit 4 Motivation and Productivity

Theories of motivation, Leadership styles and Managerial grid. Co-ordination, monitoring and control in organizations. Techniques of control; Few Cases on current management issues in India

TEXT BOOKS:

1. Schermerhorn, Management and Organisational Behaviour essentials, Wiley India
2. Koontz: Essentials of Management, PHI Learning.
3. Hirschey: Managerial Economics, Cengage Learning.
4. A V Rau: Management Science, BSP, Hyderabad
5. Mote, I Paul and Gupta: Managerial Economics Concepts & Cases, TMH, New Delhi.
6. Stephan R Robbins Fundamental of Management, Pearson

REFERENCE BOOKS

1. Koontz, H., and Weihrich, H., Essentials of Management: An International Perspective, 8th ed., McGraw Hill, 2009.
2. Hicks, Management: Concepts and Applications, Cengage Learning, 2007.
3. Mahadevan, B., Operations Management, Theory and Practice, Pearson Education Asia, 2009
4. Kotler, P., Keller, K.L, Koshy, A., and Jha, M., Marketing Management, 13th ed., 2009.
5. Khan, M.Y., and Jain, P.K., Financial Management, Tata-Mcgraw Hill, 2008.

12. Teaching and Learning Strategy

All materials (ppts, assignments, labs, etc.) will be uploaded in Moodle. Refer to your course in Moodle for details.

Course Structure & Syllabus of B.Tech.– Petroleum Engineering

Applicable for Batch: 2021-25

1. Department offering the course	Humanities & Liberal Arts
2. Course Code	LAF381
3. Course Title	Positive Psychology and Living
4. Credits (L:T:P:C)	3:0:0:3
5. Contact Hours (L:T:P)	3:0:0
6. Prerequisites (if any)	NIL
7. Course Basket	Humanities & Liberal Arts

8. Course Summary

This course provides an introduction to the science related to happiness, well-being, flourishing and the positive aspects of human experience. This course discusses research findings in the field of positive psychology. It also features practical applications of this science that you can put to use immediately to help you live a full and meaningful life.

9. Course Objectives

The purpose of this course is to provide increase awareness for relevance of positive emotions at workplace. Students will gain psychological skills to maximize happiness and virtues like compassion, love and wisdom through experiential, workshop based and interactive activities along with assigned lectures and reading. Students will have an opportunity to explore the concepts (e.g., biological, psychological, social, emotional), the research behind the concepts, and evidence-based experiential activities that enhance well-being. Students will engage in a detailed analysis and evidence-based positivity change process utilizing validated questionnaires and positive psychology and well-being enhancing interventions.

10. Course Outcomes

On successful completion of the course, students will be able to achieve the following:

1. Students learn about modern psychological knowledge of happiness.
2. Students acquire skills to cultivate positive emotions.
3. Measure and build individual, workplace and educational flourishing; plan, implement and assess positive psychology.
4. Students will gain an understanding of what contributes to well-being and how to build the enabling conditions of a life worth living.

11. Curriculum Content

Unit 1: What is positive psychology?

Introducing Positive Psychology: Definition, goals, assumptions, key concepts and relationships with health psychology, developmental psychology, social psychology and psychology of religion, Meaning and measure of Happiness: Hedonic and Eudemonic perspective, Yogic notion of bliss

Unit 2: Positive Emotions, Cognitive states and Well-being

What are positive emotions? The broaden and build theory, relevance of positive emotional states for physical, social & psychological resources, Positive emotions and well-being: Happiness and positive

Course Structure & Syllabus of B.Tech.– Petroleum Engineering

Applicable for Batch: 2021-25

behavior, positive emotions and success, resilience, Self-efficacy, Optimism, Hope, Wisdom, Mindfulness and flourishing

Unit 3: How to enhance well-being?

Use of postures, breathing practices, Sounds, dietary consumption

Unit 4: Positive Psychology at work place

Maximizing achievement, conflict resolution, gratitude, positive leadership

Textbook(s)

Snyder (2011). Positive Psychology: The Scientific and Practical Explorations of Human Strengths. New Delhi: Sage.

Reference Books

1. Carr, A. (2004). Positive Psychology: The science of happiness and human strength.UK: Routledge.
2. Peterson, C. (2006). A Primer in Positive Psychology. New York: Oxford University Press.
3. Seligman, M.E.P. (2002). Authentic Happiness: Using the New Positive Psychology to Realize YourPotential for Lasting Fulfillment. New York: Free Press/Simon and Schuster.
4. Snyder, C.R., & Lopez,S.J.(2007). Positive psychology: The scientific and practical explorations of human strengths. Thousand Oaks, CA: Sage.
5. Snyder, C. R., & Lopez, S. (Eds.). (2002). Handbook of positive psychology. New York: Oxford University Press.

12. Teaching and Learning Strategy

All materials (ppts, assignments, labs, etc.) will be uploaded in Moodle. Refer to your course in Moodle for details.

Course Structure & Syllabus of B.Tech.– Petroleum Engineering

Applicable for Batch: 2021-25

1. Department offering the course	Humanities & Liberal Arts
2. Course Code	LAF382
3. Course Title	Engineering Economics
4. Credits (L:T:P:C)	3:0:0:3
5. Contact Hours (L:T:P)	3:0:0
6. Prerequisites (if any)	NIL
7. Course Basket	Humanities & Liberal Arts

8. Course Summary

The course is devoted to teach basic concept of economics to the student of engineering. This includes basic concept of demand and supply of goods and services. Break-even point and evaluation is also included in this subject. Project evaluation and depreciation of physical assets are also key contribution in this subject. Finally, few concepts of banking system, inflation and business cycle are also the vital topics in this subject.

9. Course Objectives

- To provide the basic overview of economics in engineering perspectives.
- To increase the understanding of students to solve the engineering problems through economic theories.
- To increase the understanding of students to use economics theories in project investment of industries

10. Course Outcomes

On successful completion of the course, students will be able to achieve the following:

- Students will be able to apply economic principles and calculations to solve engineering projects.
- To students will be efficient to get the idea of production activities and its applications in industries
- Students will be competent to estimate the present and future value of money on their various investment plans.
- Develop the ability to account for time value of money using engineering economy factors and formulas, as well as the implications and importance of considering taxes, depreciation, and inflation.

11. Curriculum Content

Unit 1 General Overview of Economics

Nature and Scope of Economics in engineering perspective; **Theory of Demand Analysis:** Meaning and Types, Law of demand, Exceptions to the Law of Demand, Elasticity of Demand; **Theory of Supply Analysis:** Law of Supply and Elasticity of Supply; Mathematical Explanation on cost, revenue and profit function

Unit 2 Production Function and Its Applications

Production Function: Short-run and long-run Production Function; **Mathematical Explanation:** Laws of Returns to Scale & Law of Diminishing Returns Scale; **Concept of Cost and Its Types:** Total cost, fixed cost, variable cost, average variable cost, average fixed cost, marginal cost, explicit and implicit cost; **Break-Even-Analysis:** Importance and graphical presentation, mathematical problems

Course Structure & Syllabus of B.Tech.– Petroleum Engineering

Applicable for Batch: 2021-25

Unit 3 Time Value of Money and Project Evaluation

Time Value of Money: Simple and Compound, Uniform Series Compound Interest Formula, Present Worth Analysis, Future Worth Analysis, Future Value through Annuity, Rate of Return Analysis, Cash flow diagrams; **Depreciation:** Introduction, Straight Line and Declining Balance Method of Depreciation; **Project Evaluation Techniques:** Present Worth Method, Future Worth Method, Annual Worth Method; **Benefit Cost Analysis:** Conventional and Modified B/C Ratio with PW method

Unit 4 Banking and Finance

Banking Sector: Functions of the Commercial Bank and Central Bank, Financial Institutions; **Financial Market:** Money Market and Capital Market; **Monetary and Fiscal Policy:** Objectives, Instruments, Tools in Indian Economy; **Inflation:** Causes, Effects and Methods to Control it, Measurement of Inflation- Consumer Price Index and Whole Price Index; Deflation and Stagflation; **Business Cycles:** Various phases, Control and Measurement, Impact on business cycles on economic activities

TEXT BOOKS TEXT BOOKS

1. Pravin Kumar (2015). Fundamental of Engineering Economics. Raj Kamal Press, New Delhi.
2. Riggs J.L., Dedworth, Bedworth D.B., and Randhawa, S.U. (1996). Engineering Economics. McGraw Hill International, New Delhi
3. PanneerSelvam R. (2001). Engineering Economics. Prentice Hall of India Ltd, New Delhi.

REFERENCE BOOK

1. L.M. Bhole (2007). Financial Institutions and Markets. Tata McGraw Hill, New Delhi.

12. Teaching and Learning Strategy

All materials (ppts, assignments, labs, etc.) will be uploaded in Moodle. Refer to your course in Moodle for details.

Course Structure & Syllabus of B.Tech.– Petroleum Engineering

Applicable for Batch: 2021-25

1. Department offering the course	Humanities & Liberal Arts
2. Course Code	LAF481
3. Course Title	Application of Psychology
4. Credits (L:T:P:C)	3:0:0:3
5. Contact Hours (L:T:P)	3:0:0
6. Prerequisites (if any)	NIL
7. Course Basket	Humanities & Liberal Arts

8. Course Summary

This course will introduce students about knowledge in the various domains of psychology and its applications. It also includes theories of self, work motivation, job satisfaction, attitude and stress and its management.

9. Course Objectives

The purpose of this course is to develop a broad base of knowledge in the various domains of psychology and its applications. This course is also about to synthesis and demonstrates of useful skills in the field of psychology namely areas of organization, society, stress management etc.

10. Course Outcomes

On successful completion of the course, students will be able to achieve the following:

- The students will be able to understand basic concepts of psychology in major domains.
- The students will be able to apply the fundamentals of psychology in order to solve real life problems.
- The students will Use scientific reasoning to interpret psychological phenomena.
- To apply ethical standards to evaluate psychological science and practice

11. Curriculum Content

Unit 1: Role of Psychology in Understanding the Self

Three Stages – Self-awareness, Self-acceptance and Self-realization; Exploration through JOHARI Window; Development of Self-Mead & Cooley

Unit 2: Application of Psychology at Work Place

Work Motivation: Theories and applications: Maslow, Herzberg, Goal Setting, Emotion: Emotional Quotient & Job Satisfaction, Early approaches to leadership, contemporary approaches to leadership- Transformational & Transactional Leadership, styles of leadership

Unit 3: Application of Psychology in Personal & Professional Excellence

Achieving Success: Creativity & Innovation; Role of attitude; Role of competence; Role of Self-confidence; Time management; Role of Human Values.

Course Structure & Syllabus of B.Tech.– Petroleum Engineering

Applicable for Batch: 2021-25

Unit 4: Role of Psychology in Health & Fitness

Stress & Coping Strategies: Meaning, Types, Sources, Effects of stress on health, and coping strategies; Characteristics of a healthy personality

Textbook(s)

4. R. Bayne, and I. Horton, Applied Psychology, Sage publications, 2003.
5. A. Furnham, The Psychology of Behaviour at Work, Psychology Press, 1997.
6. D. Harris, Engineering Psychology and Cognitive Ergonomics, Aldershot: Ashgate, 1997

Reference Books

4. Baron, R.A. and Misra, G., Psychology (Indian Subcontinent Edition). Person Education Ltd. (2014).
5. Ciccarelli, S.K. & Meyer, G.E., Psychology (South Asian Edition). New Delhi: Tata Mc Graw Hill. (2008).
6. Passer, M.W., Smith, R.E., Holt, N. and Bremner, A., Psychology: The Science of Mind and Behavior, McGraw-Hill Education, UK. (2008).
7. R. Gifford, (Ed.), Applied psychology: Variety and opportunity, Allyn and Bacon, 1991.
8. M.L. Blum, and J.C. Naylor, Industrial Psychology, CBS Publishers & Distributors, 1984.
9. D.M. Pestonjee, Stress and Coping: The Indian Experience, 2nd ed., Sage Publications, 1999.

13. Teaching and Learning Strategy

All materials (ppts, assignments, labs, etc.) will be uploaded in Moodle. Refer to your course in Moodle for details.

Course Structure & Syllabus of B.Tech.– Petroleum Engineering

Applicable for Batch: 2021-25

1. Department offering the course	Humanities & Liberal Arts
2. Course Code	LAF482
3. Course Title	Intellectual Property Rights
4. Credits (L:T:P:C)	3:0:0:3
5. Contact Hours (L:T:P)	3:0:0
6. Prerequisites (if any)	NIL
7. Course Basket	Humanities & Liberal Arts

8. Course Summary

The course offers a comprehensive intellectual property subject that is easy to understand for students. The intellectual property rights syllabus comprises topics ranging from patent registration to copyrights and trademarks, and examples are based on familiar situations that the students encounter in their day-to-day lives. Topics would include the major aspects of IPR, which include analysing an idea, patent search techniques, which also helps them to boost their career with additional industry-relevant skills.

9. Course Objectives

The purpose of this course is to provide the basic understanding of intellectual property rights, the rationale behind making provision for these rights and the recent concerns in the field. The main objective of the course is to increase the attention of students to protect their IP through legal provision and also teach the students how they can reduce the imitation rate. This course also helps to teach the students the understanding their involvement in technology transfer and commercialization.

10. Course Outcomes

On successful completion of the course, students will be able to achieve the following:

6. The students will be able to understand the importance of IPRs in academic field.
7. The student gets idea how they can protect their IP through IPRs regime.
8. The student gets more incentive towards technology transfer and commercialization
9. Apply intellectual property law principles (including copyright, patents, designs and trademarks) to real problems and analyse the social impact of intellectual property law and policy

11. Curriculum Content

Unit 1: Introduction to IP

Public Funded Research and Its Implications in an Economy; Public Funded Research and Economic Development; Research & Development and Industrial Development

Unit 2: Historical Perspectives of IPRs

History and concept of Property; Introduction to intellectual property rights (IPRs); Patent, Industrial design; Copyrights, Trademarks, Geographical Indications; Trade Secrets; International aspect of IPRs; Development at International level regarding IPRs

Unit 3: Polices on IPRs in India

Course Structure & Syllabus of B.Tech.– Petroleum Engineering

Applicable for Batch: 2021-25

The debate: Copyright vs Copy left; Research ethics; role of IPRs in economic development in developed and developing economies; Overview of Various Policies on IPRs in India; Success Story of Bayh Dole Act of IPRs in USA

Unit 4: IPRs and Technology Commercialization

Technology Transfer and Commercialization; Key Determinants and Participants of Technology Transfer and Commercialization; Types of Technology Transfer and Commercialization; Technology Transfer and Commercialization in India and Other Developing Economies

Textbook(s)

1. Cornish, W.R. and L. David. 2010. 7th Edition. Intellectual Property: Patents, Copyrights, Trademarks and Allied Rights. Sweet and Maxwell.
2. Narayan, P. 2002. Intellectual Property, Law in India, 3rd Ed. New Delhi, Delhi Law House.
3. Ganguli, P. 2001. Intellectual Property Rights: Unleashing the Knowledge Economy. Tata McGraw Hills.
4. Watal, J. 2001. Intellectual Property Rights in the WTO and Developing Countries. New Delhi: Oxford University Press.

Reference Books

1. Singh A.K., Ashraf S.N. and Acharya S.R. 2017. Viability of Bayh Dole Act of USA in the context of India: Critical evidence from review of literature, in Sasi Misra.
2. Sunil Shukla and Ganapathi Batthini (Eds). Proceedings of the 12th Biennial Conference on Entrepreneurship Organized by EDII Ahmedabad (pp. 235-252). Bookwell Publishing House: New Delhi

12. Teaching and Learning Strategy

All materials (ppts, assignments, labs, etc.) will be uploaded in Moodle. Refer to your course in Moodle for details.

Course Structure & Syllabus of B.Tech.– Petroleum Engineering

Applicable for Batch: 2021-25

1.	Department offering the course	Humanities & Liberal Arts
2.	Course Code	LAF285
3.	Course Title	Indian Constitution
4.	Credits (L:T:P:C)	2:0:0:2
5.	Contact Hours (L:T:P)	2:0:0
6.	Prerequisites (if any)	NIL
7.	Course Basket	AEC

8. Course Summary:

The Constitution of India is the supreme law of India. The document lays down the framework demarcating fundamental political code, structure, procedures, powers, and duties of government institutions and sets out fundamental rights, directive principles, and the duties of citizens. The course will provide knowledge of their constitutional rights to the students and also familiarize the students with the features of the Indian Constitution.

9. COURSE OBJECTIVE:

- To familiarize the students with the features of the Indian Constitution
- To provide a knowledge of their constitutional rights

10. Course Outcomes

On successful completion of the course, students will be able to achieve the following:

- Enable the students to protect their rights
- The students will be engaged in the political system of India

11. Curriculum Content

Unit 1: Introduction

Constitution- meaning of the term, basic features Indian Constitution: Sources and constitutional history, Features: Citizenship, Preamble, Fundamental Rights and Duties, Directive, Principles of State Policy, debates on Fundamental Rights and Directive

Unit 2: Union Government and its Administration

Structure of the Indian Union: Federalism, Centre- State relationship, President: Role, power and position, PM and Council of ministers, Cabinet and Central Secretariat, Lok Sabha, Rajya Sabha Institutional Functioning: Prime Minister, Parliament and Judiciary, Power Structure in India: Caste, class and patriarchy

Unit 3: State Government and its Administration

Governor: Role and Position, CM and Council of ministers, State Secretariat: Organisation, Structure and Functions.

Unit-4 Local Administration

District's Administration head: Role and Importance, Municipalities: Introduction, Mayor and role of Elected, Representative, CEO of Municipal Corporation, Pachayati raj: Introduction, PRI: Zila Pachayat, Elected officials and their roles, CEO Zila Pachayat: Position and role, Block level: Organizational Hierarchy (Different departments), Village level: Role of Elected and Appointed officials, Importance of grass root democracy

Course Structure & Syllabus of B.Tech.– Petroleum Engineering

Applicable for Batch: 2021-25

Unit 5: Election Commission

Election Commission: Role and Functioning, Chief Election Commissioner and Election Commissioners, State Election Commission: Role and Functioning, Institute and Bodies for the welfare of SC/ST/OBC and women

TEXT BOOKS

1. Abbas, H., Kumar, R. & Alam, M. A. (2011) Indian Government and Politics. New Delhi: Pearson, 2011.
2. Chandhoke, N. & Priyadarshi, P. (eds.) (2009) Contemporary India: Economy, Society, Politics. New Delhi: Pearson.

REFERENCE BOOKS

1. Chakravarty, B. & Pandey, K. P. (2006) Indian Government and Politics. New Delhi: Sage.
2. Chandra, B., Mukherjee, A. & Mukherjee, M. (2010) India After Independence. New Delhi: Penguin.
3. Singh, M.P. & Saxena, R. (2008) Indian Politics: Contemporary Issues and Concerns. New Delhi: PHI Learning.
4. Vanaik, A. & Bhargava, R. (eds.) (2010) Understanding Contemporary India: Critical Perspectives. New Delhi: Orient Blackswan.

12 Teaching and Learning Strategy

All materials (ppts, assignments, labs, etc.) will be uploaded in Moodle. Refer to your course in Moodle for details.

Course Structure & Syllabus of B.Tech.– Petroleum Engineering

Applicable for Batch: 2021-25

1. Department offering the course	Petroleum and Energy Studies
2. Course Code	PEF215
3. Course Title	Python for Oil and Gas
4. Credits (L:T:P:C)	1:0:1:2
5. Contact Hours (L:T:P)	1:0:2
6. Prerequisites (if any)	None
7. Course Basket	SEC

8. Course Summary

This course introduces the basics of Python 3, including conditional execution and iteration as control structures, and strings and lists as data structures. This course also covers the dictionary data structure, user-defined functions, classes and inheritance as well as the data collection and pre-processing from external sources.

9. Course Objectives

The objective of this course is to provide basic understanding of working in Python environment to write and execute programs for solving problems I oil and gas industry.

10. Course Outcomes

On successful completion of the course, students have the understanding of the following:

6. Understand the Python programming environment and data.
7. Be able to Work with strings, lists and tuples and apply various operators.
8. Apply loops and execute conditionals and logical operators.
9. Be able to work with data files and dictionaries.
10. Be able to work with iterations, functions, and classes.

11. Curricula

m Content UNIT 1:

Installing and Understanding Python Environment, Python Libraries, Data Types and Variables.

UNIT 2:

Operators and Operands, Statements and Expressions, Strings, Lists, Tuples.

UNIT 3:

Working with For Loop, Boolean Expressions, Logical Operators, Conditional Execution.

UNIT 4:

Sequence Mutation and Accumulation Patterns, Working with Data Files, Dictionaries and Dictionary Accumulation.

UNIT 5:

Iteration and Advanced Functions, Basic Sortings, Python Classes and Inheritance.

Course Structure & Syllabus of B.Tech.– Petroleum Engineering

Applicable for Batch: 2021-25

List of Experiments:

1. Setting up the Python Environment, understanding the interface and python libraries.
2. Working with different data types and variables.
3. Plotting and visualizing data with python.
4. Working with statements, expressions and operators.
5. Working with loops and accumulation pattern.
6. Working with conditionals, sequences and dictionaries.
7. Open, write and read data from .txt and .csv files.
8. Define and call functions for case problems.
9. Using basic sorting methods and classes.

Text book [TB]:

1. Mark Lutz; Programming Python; 4th Edition; O'Reilly Media, Inc.; 2010.

Reference books [RB]:

1. Brian K. Jones and David M. Beazley; Python Cookbook: Recipes for Mastering Python 3; 3rd edition; O'Reilly Media; 2013.

Course Structure & Syllabus of B.Tech.– Petroleum Engineering

Applicable for Batch: 2021-25

1. Department offering the course	Petroleum and Energy Studies
2. Course Code	PEF305
3. Course Title	Petroleum Data Analytics
4. Credits (L:T:P:C)	1:0:1:2
5. Contact Hours (L:T:P)	1:0:2
6. Prerequisites (if any)	None
7. Course Basket	SEC

8. Course Summary

This course deals with data preparation, data analysis and data analytics techniques. The course includes examples of analytics in various sectors of petroleum industry.

9. Course Objectives

The objective of this course is to provide students the basic skills to apply the data analytics approaches in petroleum data analytics.

10. Course Outcomes

On successful completion of the course, students have the understanding of the following:

1. Understand basics of data, data analysis and data analytics.
2. Perform data preparation and visualization.
3. Apply the probability distribution for data analytics.
4. Apply statistical analysis and hypothesis testing for data analysis.
5. Perform regression and clustering analysis for petroleum data.

11. Curriculum

Content UNIT 1:

Introduction to data analytics, data analysis vs. data analytics, data analytics classification, Type of data.

UNIT 2:

Sources of data, data wrangling, data cleaning and preparation, data mining, data visualization.

UNIT 3:

Probability theory, probability distribution (discrete and continuous), sampling and sampling Distribution.

UNIT 4:

Confidence interval estimation, hypothesis testing, chi-square goodness of fit test, ANOVA.

UNIT 5:

Linear and Logistic regression model, Cluster analysis.

List of Experiments:

1. Data handling and data preparation
2. Data wrangling and cleaning

Course Structure & Syllabus of B.Tech.– Petroleum Engineering

Applicable for Batch: 2021-25

3. Data plotting and visualization
4. Implementation of probability distribution
5. Implementation of statistical analysis and hypothesis testing
6. Implementation of simple Linear Regression model
7. Implementation of logistic regression model
8. Implementation of cluster analysis model

Text book [TB]:

1. McKinney, W. (2012). Python for data analysis: Data wrangling with Pandas, NumPy, and IPython. " O'Reilly Media, Inc."
2. Swaroop, C. H. (2003). A Byte of Python. Python Tutorial.
3. Ken Black, sixth Editing. Business Statistics for Contemporary Decision Making. "John Wiley & Sons, Inc".

Reference books [RB]:

1. Jay L. Devore (2011). Probability and Statistics for Engineering and the Sciences. "Cengage Learning".
2. David W. Hosmer, Stanley Lemeshow (2000). Applied logistic regression (Wiley Series in probability and statistics). "Wiley-Interscience Publication".

Course Structure & Syllabus of B.Tech.– Petroleum Engineering

Applicable for Batch: 2021-25

1. Department offering the course	Petroleum and Energy Studies
2. Course Code	PEF315
3. Course Title	Machine Learning in Petroleum Operations
4. Credits (L:T:P:C)	1:0:1:2
5. Contact Hours (L:T:P)	1:0:2
6. Prerequisites (if any)	None
7. Course Basket	SEC

8. Course Summary

This course will provide an introduction to techniques, and algorithms in machine learning including classification and regression. The course will give the student the basic ideas and intuition behind modern machine learning methods and their applications in petroleum operations.

9. Course Objectives

This course is designed to provide knowledge about basic concepts of Machine Learning, identify machine learning techniques suitable for petroleum engineering problems, and solve the problems using various machine learning techniques.

10. Course Outcomes

On successful completion of the course, students have the understanding of the following:

1. Understand the basics of machine learning.
2. Understand and apply regression and clustering methods.
3. Understand and apply Bayesian and K-Nearest Neighbours methods.
4. Understand and apply classification methods.
5. Understand and apply dimensionality reduction techniques.

11. Curriculum

Content UNIT 1:

Overview of machine learning: Unsupervised, Supervised, Reinforcement, machine learning problems, components of learning, types of learning. Aspects of developing a learning system: training data, concept representation, function approximation.

UNIT 2:

Regression: Univariate Linear Regression and Multivariate Regression. Clustering: Distance measures, Different clustering methods (Distance, Density, Hierarchical), Iterative distance- based clustering, dealing with continuous, categorical values in K-Means.

UNIT 3:

Classification: Bayesian Learning (Bayes theorem, Bayes Optimal Classifier, Naïve Bayes classifier), K-Nearest Neighbors.

UNIT 4:

Support Vector Machines, Decision Trees, Boosted Trees, Random Forest, CART, Gradient boosting.

Course Structure & Syllabus of B.Tech.– Petroleum Engineering

Applicable for Batch: 2021-25

UNIT 5:

Dimensionality Reduction: Feature selection, principal component analysis, linear discriminant analysis, factor analysis, independent component analysis, multidimensional scaling, manifold learning, band selection.

List of Experiments:

1. Data Handling (Downloading Dataset, Import/Export Dataset Files, Summarization of dataset)
2. Data Pre-processing (Missing Value, Outlier Handling, Formatting data)
3. Implementation of Linear Regression with one variable
4. Implementation of Linear Regression with multiple variable
5. Implementation of Logistic Regression
6. Implementation of Decision Tree
7. Implementation of k-Nearest Neighbours
8. Implementation of Support Vector Machine
9. Implementation of K-means clustering

Text book [TB]:

1. Tom Mitchell, Machine Learning, McGraw Hill, 1st edition, 2013.
2. Ethem Alpaydin, Introduction to Machine Learning, PHI, 3rd edition, 2015.

Reference books [RB]:

1. Christopher Bishop, Pattern Recognition and Machine Learning, Springer, 2nd edition, 2013.
Stephen Marsland, Machine Learning: An Algorithmic Perspective, CRC Press, 2nd edition, 2014.

Course Structure & Syllabus of B.Tech.– Petroleum Engineering

Applicable for Batch: 2021-25

1. Department offering the course	Petroleum and Energy Studies
2. Course Code	PEF316
3. Course Title	Applied Deep Learning for Predictive Modeling of Petroleum Reservoirs
4. Credits (L:T:P:C)	1:0:1:2
5. Contact Hours (L:T:P)	1:0:2
6. Prerequisites (if any)	None
7. Course Basket	SEC

8. Course Summary

This course aims to provide a basic understanding of deep learning concepts, implementation of deep learning algorithms for predictive modelling of petroleum system.

9. Course Objectives

The objective of this course is to cover the fundamentals of neural networks as well as some advanced topics such as recurrent neural networks, long short term memory cells and convolutional neural networks. The course also requires students to implement programming assignments related to these topics in the field of petroleum engineering.

10. Course Outcomes

On successful completion of the course, students have the understanding of the following:

1. Understand the basics of neural networks.
2. Understand and apply neural network techniques.
3. Understand and apply convolutional neural networks.
4. Understand and apply recurrent neural networks.
5. Understand and apply GRU and Bi – RNNs.

11. Curriculum

Content UNIT 1:

Introduction to Neural Networks: Introduction to Biological Neural Network, Artificial Neural Network. Activation Functions, Basic Learning rules, Biases, Hyperparameter, Cost Function, Applications of Artificial Neural Networks.

UNIT 2:

Neural Network Techniques: Gradient Descent, Stochastic Gradient Descent, Back Propagation, Multi-Layer Perceptron, Feed Forward Networks.

UNIT 3:

Convolutional Neural Networks, LeNet, AlexNet and ResNet.

UNIT 4:

Recurrent Neural Networks: Back propagation through time, Long Short Term Memory.

UNIT 5:

Gated Recurrent Units, Bidirectional LSTMs, Bidirectional RNNs.

Course Structure & Syllabus of B.Tech.– Petroleum Engineering

Applicable for Batch: 2021-25

List of Experiments:

1. Data Handling (Downloading Dataset, Import/Export Dataset Files, Summarization of dataset)
2. Data Pre-processing (Missing Value, Outlier Handling, Formatting data)
3. Implementation of artificial neural networks
4. Implementation of convolutional neural networks
5. Implementation of recurrent neural networks
6. Implementation of long short – term memory networks
7. Importing pre – trained models
8. Implementation of pre – trained models with new learning model

Text book [TB]:

1. Deep Learning”, Ian Goodfellow and Yoshua Bengio and Aaron Courville, MIT Press, 2016.

Reference books [RB]:

1. “Neural Networks: A Systematic Introduction”, Raúl Rojas, 1996
2. Pattern Recognition and Machine Learning, Christopher Bishop, 2007.

Course Structure & Syllabus of B.Tech.– Petroleum Engineering

Applicable for Batch: 2021-25

1. Department offering the course	Humanities & Liberal Arts
2. Course Code	LAF184
3. Course Title	Corporate Communication and Soft Skills
4. Credits (L:T:P:C)	2:0:2:3
5. Contact Hours (L:T:P)	2:0:2
6. Prerequisites (if any)	NIL
7. Course Basket	Language and Literature

8. Course Summary

This course is to enhance the soft skills of the students. It also focuses on Business communication. It will help the students to develop professional skills and how to be effective communicator at work place.

9. Course Objectives

- To introduce to students to the business & corporate environment and its expectations.
- To help students to identify and sharpen their personal and professional skills.
- To ensure employability of students through a perfect blend of hard & soft skills.

10. Course Outcomes

On successful completion of the course, students will be able to achieve the following:.
Students identify their goals and through enhanced soft skills work towards achieving them.

- Greater self-confidence and knowledge of life skills helps them to develop healthier interpersonal relationships.
- Prepares the students to face future challenges and excel in their personal and professional lives.

Unit 1

Business Communication

8hrs

Importance & Features of Business Communication, Flow of Communication: Channels & Networks

Business Presentation

Business Etiquette, Telephonic Etiquette

Interview Skills, Impression Management

Unit 2

8hrs

Business Letter Writing

Job Application Letter & Resume

Communication: E mails & E- Tools

Course Structure & Syllabus of B.Tech.– Petroleum Engineering

Applicable for Batch: 2021-25

Unit 3

Personal Skills for Corporate Communication

8hrs

SWOT Analysis: Self-Assessment, Identifying Strength & Weakness

Self-Awareness, Self-Disclosure & Self-Management (Stress, Anger)

Goal Setting: Personal & Professional Goals, SMART-ER Goals

Human Perception: Understanding People, Perceptions, Attitudes

Personality (Personality Test)

Unit 4

8hrs

Professional Skills for Corporate Communication

Decision Making: Techniques, Six Thinking Hats

Creative Thinking, Lateral Thinking

Team Building & Leadership Skills

Time Management: Planning Organizing, Time Wasters

Conflict Resolution Skills

Negotiation Skills

Lab 1 Telephone Etiquette: Making an appointment, answering calls (Role Play)

Lab 2 Telephone Etiquette: Making an appointment, answering calls (Role Play)

Lab 3 Business Presentations (PPT Presentation)

Lab 4 Business Presentations (PPT Presentation)

Lab 5 Interview Skills: Mock Interview

Lab 6 Interview Skills: Mock Interview

Lab 7 Panel Discussion

Lab 8 Panel Discussion

Lab 9 Conflict & Negotiation(Situational Role Play)

Lab 10 Conflict & Negotiation (Situational Role Play)

Lab 11 Evaluation

Lab 12 Evaluation

Course Structure & Syllabus of B.Tech.– Petroleum Engineering

Applicable for Batch: 2021-25

TEXT BOOKS

1. Rizvi, Ashraf. Effective Technical Communication, McGraw Hill, New Delhi. 2005.
2. Gulati, Sarvesh. Corporate Soft skills, Rupa & Company, 2006

REFERENCE BOOKS

1. Steven R. Covey. The Seven Habits of Highly Effective People, Simon and Schuster, London, 2007.
2. Robbins, Stephen. Management, Pearson Prentice Hall. 2009
3. Carnegie, Dale. How to win Friends and influence People, Simon and Schuster, London, 2009.
4. Dr. Alex. Soft Skills: Know Yourself & Know the World, S. Chand Publications, 2001.
5. Gopalswamy, Ramesh. The ACE of Soft Skills: Attitude, Communication and Etiquette for Success, Pearson, New Delhi, 2008.
6. Ghosh, B. N. Managing Soft skills for Personality development, Laxmi Publications Ltd., New Delhi, 2013.
7. Elizabeth B. Hurlock. Personality Development, TMH Publication, 2010.

1. Teaching and Learning Strategy

All materials (ppts, assignments, labs, etc.) will be uploaded on online platform.

Course Structure & Syllabus of B.Tech.– Petroleum Engineering

Applicable for Batch: 2021-25

1. Department offering the course	School of Liberal Arts & Management
2. Course Code	LAF285
3. Course Title	Indian Constitution
4. Credits (L:T:P:C)	2:0:0:2
5. Contact Hours (L:T:P)	2:0:0
6. Prerequisites (if any)	NIL
7. Course Basket	Humanities & Liberal Arts

8. Course Summary:

The Constitution of India is the supreme law of India. The document lays down the framework demarcating fundamental political code, structure, procedures, powers, and duties of government institutions and sets out fundamental rights, directive principles, and the duties of citizens. The course will provide knowledge of their constitutional rights to the students and also familiarize the students with the features of the Indian Constitution.

9. COURSE OBJECTIVE:

- To familiarize the students with the features of the Indian Constitution
- To provide a knowledge of their constitutional rights

10. Course Outcomes

On successful completion of the course, students will be able to achieve the following:

- Enable the students to protect their rights
- The students will be engaged in the political system of India

11. Curriculum Content

Unit 1: Introduction

Constitution- meaning of the term, basic features Indian Constitution: Sources and constitutional history, Features: Citizenship, Preamble, Fundamental Rights and Duties, Directive, Principles of State Policy, debates on Fundamental Rights and Directive

Unit 2: Union Government and its Administration

Structure of the Indian Union: Federalism, Centre- State relationship, President: Role, power and position, PM and Council of ministers, Cabinet and Central Secretariat, Lok Sabha, Rajya Sabha Institutional Functioning: Prime Minister, Parliament and Judiciary, Power Structure in India: Caste, class and patriarchy

Unit 3: State Government and its Administration

Course Structure & Syllabus of B.Tech.– Petroleum Engineering

Applicable for Batch: 2021-25

Governor: Role and Position, CM and Council of ministers, State Secretariat: Organisation, Structure and Functions.

Unit-4 Local Administration

District's Administration head: Role and Importance, Municipalities: Introduction, Mayor and role of Elected, Representative, CEO of Municipal Corporation, Pachayati raj: Introduction, PRI: Zila Pachayat, Elected officials and their roles, CEO Zila Pachayat: Position and role, Block level: Organizational Hierarchy (Different departments), Village level: Role of Elected and Appointed officials, Importance of grass root democracy

Unit 5: Election Commission

Election Commission: Role and Functioning, Chief Election Commissioner and Election Commissioners, State Election Commission: Role and Functioning, Institute and Bodies for the welfare of SC/ST/OBC and women

TEXT BOOKS

1. Abbas, H., Kumar, R. & Alam, M. A. (2011) Indian Government and Politics. New Delhi: Pearson, 2011.
2. Chandhoke, N. & Priyadarshi, P. (eds.) (2009) Contemporary India: Economy, Society, Politics. New Delhi: Pearson.

REFERENCE BOOKS

1. Chakravarty, B. & Pandey, K. P. (2006) Indian Government and Politics. New Delhi: Sage.
2. Chandra, B., Mukherjee, A. & Mukherjee, M. (2010) India After Independence. New Delhi: Penguin.
3. Singh, M.P. & Saxena, R. (2008) Indian Politics: Contemporary Issues and Concerns. New Delhi: PHI Learning.
4. Vanaik, A. & Bhargava, R. (eds.) (2010) Understanding Contemporary India: Critical Perspectives. New Delhi: Orient Blackswan.

12 Teaching and Learning Strategy

All materials (ppts, assignments, labs, etc.) will be uploaded in Moodle. Refer to your course in Moodle for details.

Course Structure & Syllabus of B.Tech.– Petroleum Engineering

Applicable for Batch: 2021-25

1. Department offering the course	School of Liberal Arts & Management
2. Course Code	LAF286
3. Course Title	Youth Psychology
4. Credits (L:T:P:C)	3:0:0:3
5. Contact Hours (L:T:P)	3:0:0
6. Prerequisites (if any)	NIL
7. Course Basket	Humanities & Liberal Arts

8. Course Summary

This course will introduce students about the youth, identity and development related issues. The course explores the risk factors of a youth such as education. It explores the development of youth in the society. The course will through study of text, also analyse the practical aspect of it.

9. Course Objectives

To help students understand the notion of youth, youth across cultures, the factors influencing youth identity and sensitivity to issues concerning the youth of today.

10 Course Outcomes

On successful completion of the course, students will be able to achieve the following:

1. Students will get to know about concepts of youth, youth identity.
2. Students will learn about the process of youth development and relationship.
3. Students will learn to how a youth could develop on his own.
4. Students will learn about relevance of positive virtues during young age.

1. Curriculum Content

Unit 1: Introduction

Defining youth; Youth across cultures; Formulation of youth identity; Concerns of youth in Indian context.

Unit 2: Youth development and Relationships

Relationship with family members and friends; Romantic relationships; Youth culture: Influence of globalization, identity crisis

Unit 3: Today's Youth: Issues and challenges

Youth and risk behaviours; Employment and education

Unit 4: Developing Youth

Positive youth development; Building resources: Hope, Optimism and Resilience

Textbook(s)

1. Robbins, S. P. & Judge, T.A. (2008).Essentials of Organizational Behavior.9th Edition.

Course Structure & Syllabus of B.Tech.– Petroleum Engineering

Applicable for Batch: 2021-25

New Delhi: Prentice Hall of India.

2. Adler, N.J. (1997). Global leaders: Women of influence. In G. N. Powell (Ed.), Handbook of Gender and Work, (239-261). Thousand Oaks, CA, US: Sage Publications, Inc.

Reference Books

1. Adler, N.J. (1997). Global Leaders: A Dialogue with future history. Journal of International Management, 2, 21-33.
2. Chadha, N.K. (2007). Organizational Behavior (1st Edition). Galgotia Publishers: New Delhi.
3. Greenberg, J. & Baron, R.A. (2007). Behaviour in Organizations (9th Ed.). India: Dorling Kindersley
4. Griffin, R.W. & Moorhead, G. (2009). Organizational Behavior: Managing People & Organizations (11th Edition). Biztantra publishers

1. Teaching and Learning Strategy

All materials (ppts, assignments, labs, etc.) will be uploaded on the online platform. Refer to your course for details.

Course Structure & Syllabus of B.Tech.– Petroleum Engineering

Applicable for Batch: 2021-25

1. Department offering the course	School of Liberal Arts & Management
2. Course Code	LAF287
3. Course Title	Sustainable Development
4. Credits (L:T:P:C)	3:0:0:3
5. Contact Hours (L:T:P)	3:0:0
6. Prerequisites (if any)	NIL
7. Course Basket	Humanities & Liberal Arts

8. Course Summary

This course will introduce students about the basic Principles needed for management. It also includes case studies where a student can get idea about the actual working of the management field. Topics include Overview of Management, Management Information, and Planning Approach to Organizational Analysis, Motivation and Productivity.

9. Course Objectives

To provide the overview of sustainable and its needs to the students.

To provide the importance and components of sustainable development to the students.

To provide the association of social and economic development to the students

10. Course Outcomes

Students will get the importance of natural resource in economic development.

Students also would be able to sophisticated concept of sustainable development.

Students would be able to contribute significant efforts towards sustainable development.

11. Curriculum Content

Unit 1: Overview of Sustainable Development

History and emergence of the concept of Sustainable Development, Components of SD i.e., Economic, Social, Human, Institutional, Technological and Environmental development; Definitions, Sustainability in Ecosystem Services; natural resource degradation, greenhouse gases, factors affecting SD (i.e., Industrialization, urbanization, population growth, globalization, etc.).

Unit 2: Policies on Sustainable Development at international level

Government Policies for SD in India; Socio-economic policies for sustainable development in India, Sustainable development through trade, Carrying Capacity, global policies for sustainable development.

Unit 3: Sustainable Development and International Contribution

SDGs and MDGs, Complexity of growth and equity, International Summits, Conventions, Agreements, Initiations of international organizations like WHO, UNDP, WTO, FAO and World Bank towards sustainable development.

Course Structure & Syllabus of B.Tech.– Petroleum Engineering

Applicable for Batch: 2021-25

Unit 4: Measurement of Sustainable Development

Role of developed and developing countries in the sustainable development, Demographic dynamics and sustainability, integrated approach for resource protection and management; Index based estimation of SD i.e., Environmentally Sustainable Development Index and sustainable development, and another index.

TEXT BOOKS:

1. The Sustainability Revolution: Portrait of a Paradigm Shift by Edwards, Andres R., New Society Publishers, 2005.

REFERENCE BOOKS

1. The Sustainability Revolution: Portrait of a Paradigm Shift by Edwards, Andres R., New Society Publishers, 2005.
2. Sustainable development in India: Stocktaking in the run up to Rio+20: Report prepared by TERI for MoEF, 2011.

12. Teaching and Learning Strategy

All materials (ppts, assignments, labs, etc.) will be uploaded on online portal.

Course Structure & Syllabus of B.Tech.– Petroleum Engineering

Applicable for Batch: 2021-25

1. Department offering the course	School of Liberal Arts & Management
2. Course Code	LAF383
3. Course Title	Introduction to Linguistics
4. Credits (L:T:P:C)	2:0:2:3
5. Contact Hours (L:T:P)	2:0:2
6. Prerequisites (if any)	NIL
7. Course Basket	Humanities & Liberal Arts

8. Course Summary

The student will be able to comprehend foundational linguistic concepts and their relation with the human mind. They will understand how research in linguistics can be used to address real world problems.

9. Course Objectives

- To introduce the basic concepts in areas of linguistics, syntax, morphology, phonetics, and phonology and the interaction between them.
- To provide an understanding of the main communicative functions of language, and the formal ways to achieve them.

10. Course Outcomes

On successful completion of the course, students will be able to achieve the following:

- The student will be able to apply the basic concepts of linguistics, syntax, morphology, phonetics, and phonology
- The student will be able to appreciate the use of basic concept of linguistics.

11. Curriculum Content

Unit 1:

(10)

Linguistics and its Scope, Branches of Linguistics, Some basic concepts in Linguistics, Language and Communication

UNIT 2

(16)

Phonetics and Phonology; Phoneme, Allophone, Human Speech Mechanism, Vowels and Consonants in English Syllable structure, Phonemic Transcription, Supra-segmental features, Neutralization of MTI

Course Structure & Syllabus of B.Tech.– Petroleum Engineering

Applicable for Batch: 2021-25

UNIT 3

(15)

Language Structure Saussure's concept of Linguistic sign, Langue and Parole; Syntagmatic and Paradigmatic relations, Synchronic and Diachronic studies; Chomsky – Competence and Performance; Language Variation and Language Change

UNIT 4

(11)

Morphology and Syntax; Morpheme, Word Formation Processes in English, Roots, prefix & suffix

Learning Outcome

At the end of this course -

Text book [TB]:

1. Halliday, Michael A.K.; Jonathan Webster (2006). On Language and Linguistics. Continuum International Publishing Group. p. vii. ISBN 978-0-8264-8824-4.
2. Rens Bod (2014). A New History of the Humanities: The Search for Principles and Patterns from Antiquity to the Present. Oxford University Press. ISBN 978-0-19-966521.

Reference books [RB]:

1. Delany, Sheila. The Naked Text: Chaucer's Legend of Good Women. Berkeley: University of California Press, 1994.
2. Mc Alpine, Monica. The Genre of Troilus and Criseyde. Ithaca: Cornell University Press, 1978.
3. Brooks, Cleanth. The Language of Paradox: 'The Canonization' John Donne: A Collection of Critical Essays. Ed. Helen Gardner. Englewood Cliffs, N. J.: Prentice Hall, 1962.

12. Teaching and Learning Strategy

All materials (ppts, assignments, labs, etc.) will be uploaded on online platform.

Course Structure & Syllabus of B.Tech.– Petroleum Engineering

Applicable for Batch: 2021-25

1	Department offering the course	School of Liberal Arts & Management
2	Course Code	LAF384
3	Course Title	Creative Writing
4	Credits (L:T:P:C)	3:0:0:3
5	Contact Hours (L:T:P)	3:0:0
6	Prerequisites (if any)	NIL
7	Course Basket	Humanities & Liberal Arts

8 Course Summary

To produce graduates able to effectively communicate what it is they, as writers, do, and to effectively present literary works, their own as well as the works of others.

9 Course Objectives

To teach students how to read critically as writers – to understand other writers' craft, purposes, and aesthetic choices, toward the creation of the students' own original works. To offer students the opportunity for frequent and extensive writing, guided by teachers, supported by classmates, building upon reading and study, in order to provide an apprenticeship in the art.

10 Course Outcomes

On successful completion of the course, students will be able to achieve the following:

1. Students will be able to examine how texts function across a range of genres, contexts, and cultures.
2. Students will develop and sharpen skills in creating, editing and revising in the student's primary genre.
3. They will be able to read and respond thoughtfully .
4. Students will examine critically both oral and written form of other writers' works.

11 Curriculum Content

Unit-1

(8)

Understanding Creativity, Meaning of Creative Writing, The Art and Craft of Writing, Modes of creative Writing, Csikszentmihaly's systems model of creativity, Interplay of languages and forms of writing, Theory of Enjoyment, Creativity and culture

Unit 2 To Be a Writer

(7)

Creativity, Writing and Creative Writing: Recent Views, Writers on writing: Albert Camus, Critical reading of important writers: Margaret Atwood (Negotiating with the Dead – A Writer on Writing.

Reading and Writing, Essay Writing , Biography/Autobiography Writing

Unit 3 Short Stories

(5)

Course Structure & Syllabus of B.Tech.– Petroleum Engineering

Applicable for Batch: 2021-25

Short Story as a genre, Components of short story –Plot, Characterization, Varieties of writing process, Writing Short Story, Angela Carter: The Tiger’s Bride, John Steinbeck: Chrysanthemums, James Joyce: Araby

Unit 4 Drama

(6)

Introduction to Drama, Performance and Script Writing-Mime, Drama in the Class Room: Experience and Writing

Reference Books [RB]:

1. Neira, Anjana. Creative writing: A Beginner’s Manual. Delhi: Pearson Publication, 2009.Print.
2. Everett, Nick. Creative writing and English. The Cambridge Quarterly, 2005.Print.
3. Iversen, Kristen Dena. Shadow Boxing: Art and Craft in Creative Nonfiction. Pearson/Prentice Hall, 2003.Print.
4. Morley, David. The Cambridge Introduction to Creative Writing. Cambridge University Press, 2007.Print.

2. Teaching and Learning Strategy

All materials (ppts, assignments, labs, etc.) will be uploaded on online platform.

Course Structure & Syllabus of B.Tech.– Petroleum Engineering

Applicable for Batch: 2021-25

1. Department offering the course	School of Liberal Arts & Management
2. Course Code	LAF385
3. Course Title	Health Psychology
4. Credits (L:T:P:C)	3:1:0:4
5. Contact Hours (L:T:P)	3:1:0
6. Prerequisites (if any)	NIL
7. Course Basket	Humanities & Liberal Arts

8.Course Summary

The present investigates the relationship of social, biological, behavioral and cognition variables to health. It includes those dimensions of the social that influence health and illness result including interactions among family members and healthcare consumers and providers.

9.Course Objective

1. Demonstrate understanding of the biological, behavioral, cognitive and social determinants of health, and risk factors for health- compromising behaviours and strategies for their modification, across the lifespan.
2. Demonstrate advanced knowledge of individual, group and community-based approaches to the prevention and management of major identifiable health conditions (both acute and chronic).
3. Demonstrate the capacity to critically evaluate research in health psychology and use this knowledge to explain mind-body interaction to health-care consumers and professionals.
4. Apply the knowledge of health psychology in different domains of life

10. Curriculum Content

Unit-I: Introduction

Health Psychology: Concept, Assumptions, Models (Biomedical and Biopsychosocial)

Unit -II: Stress and Coping

Nature and sources of stress; Effects of stress on physical and mental health; Coping and stress management

Unit-III Health Promotion and Illness Prevention: Health and Behavior; Changing health habits; Cognitive behavioral approaches to health behavior change.

UNIT IV: Human strengths and life enhancement

Classification of human strengths and virtues; cultivating inner strengths: Hope and optimism; gainful Employment and Me/We Balance, Well-being and enhancement

Course Structure & Syllabus of B.Tech.– Petroleum Engineering Applicable for Batch: 2021-25

Textbook(s)

Ogden, J. (2012). Health Psychology. McCrawhill Foundation

Taylor, S.E., (2009). Health Psychology (9th Ed). New Delhi: Tata McGraw-Hill Publishing Company Ltd.

Reference Books

Ayers, S., Baum, A., McManus, C., Newman, S., Wallston, K., Weinman, J., & West, R. (2007).
Cambridg

Brannon, L., McNeese, J. F., & Updegraff, J. A. (2014). Health Psychology an introduction to
behavior and health (8th Ed). Delhi: Cengage Learning

Straub, R.O. (2014). Health Psychology a Bio Psychosocial Approach (4th Ed). Worth
Publishers A Macmillan Higher Education Company

Teaching and Learning Strategy

All materials (ppts, assignments, labs, etc.) will be uploaded on online platform.

Course Structure & Syllabus of B.Tech.– Petroleum Engineering

Applicable for Batch: 2021-25

1. Department offering the course	School of Liberal Arts & Management
2. Course Code	LAF386
3. Course Title	Ecology and Human Development
4. Credits (L:T:P:C)	3:0:0:3
5. Contact Hours (L:T:P)	3:0:0
6. Prerequisites (if any)	NIL
7. Course Basket	Humanities & Liberal Arts

8. Course Summary

This course introduces students to environment concerns. Students are expected to learn about environment, factors affecting it, environmental ethics and its protection through lectures, presentations, documentaries and field visits.

9. Course Objectives

To increase the understanding of students on ecological and its role in human livelihoods.

To demonstrate understanding of some issue of ecological development.

To provide basic information related to human utilization of resources and how human activities impact the environment.

10. Course Outcomes

On successful completion of the course, students will be able to achieve the following:

1. Students will be able to identify key issues and concepts relevant to the understanding of how human behaviour develops over the life cycle and be able to explain them to a layperson.
2. Students will be able to generate a hypothesis using a conceptual model relevant to a developmental question and identify an appropriate test of that hypothesis.
3. Students will be able to see how research findings can be applied in real-life settings.

11. Curriculum Content

Unit 1: Major Components of Ecological System; Various Ecosystem Services; Measurement of Nature; Methods to Measure the Ecosystem Services; Ecosystem Services in Developed and Developing Economies.

Unit 2: Rural Development and Ecosystem Services, Regional Diversity in Ecosystem Services, Economic Valuation of Various Ecosystem Services; Ecosystem Services of Rivers, Forestry, Soil, Air, Plants.

Unit 3: Management Policies of Ecosystem Services; Sustainability of Ecosystem Services; Inter-linkages between Economic Development and Ecosystem Services; Human Well-being and Ecosystem Services; Sustainability in Ecosystem Services.

Unit 4: Government Policies and Ecosystem Services in India; Different Mathematical and Econometric Models for Ecosystem Services; Simulation Techniques for Ecosystem Services.

Course Structure & Syllabus of B.Tech.– Petroleum Engineering

Applicable for Batch: 2021-25

12. TEXT BOOKS

1. Millennium Ecosystem Assessment (MEA) (2005). Ecosystems and Human Well-being: Synthesis. Island Press, Washington, DC.
2. Verma M. and Kumar CVRSV (2006). Natural Resource Accounting of Land and Forestry Sector (Excluding Mining) for the States of Madhya Pradesh and Himachal Pradesh. Indian Institute of Forest Management Bhopal, Bhopal (M.P.)

13. REFERENCE BOOKS

3. (2013). Human Activity and the Environment: Measuring Ecosystem goods and Services in Canada.
4. Negi G.C.S. and Dhyani PP. (2012). Glimpses of Forestry Research in the Indian Himalayan Region: Special Issue on International Year of Forests-2011. ENVIS Centre on Himalayan Ecology, G.B. Pant Institute of Himalayan Environment & Development, Kosi-Katarmal, Almora- 263643, India.
5. (2004) Valuing Ecosystem Services: Towards Better Environmental Decision-Making. National Research Council of the National Academies Press, Washington, D.C.

14. Teaching and Learning Strategy

All materials (ppts, assignments, labs, etc.) will be uploaded on online platform.

Course Structure & Syllabus of B.Tech.– Petroleum Engineering

Applicable for Batch: 2021-25

1. Department offering the course	School of Liberal Arts & Management
2. Course Code	LAF483
3. Course Title	Science, Technology & Society
4. Credits (L:T:P:C)	3:0:0:3
5. Contact Hours (L:T:P)	3:0:0
6. Prerequisites (if any)	NIL
7. Course Basket	Humanities & Liberal Arts

Course Objective

8. Course Summary

The course will help the students to understand the link between science technology and society and will be able to know the basic implications of science & technology in social growth.

9. Course Objectives

To increase the basic understanding of students towards science and technology, and basic implications of science & technology on social development.

10. Course Outcomes

1. Enable students to examine the role of science and technology in social and economic development.
2. The students will understand perspectives on relations between science and technology.
3. The student will be able to understand the scientific temper & its social significance.
4. The student will be able to understand and implement technological policies for the betterment of society.

On successful completion of the course, students will be able to achieve the following:

11. Curriculum Content

Unit 1

12 Hrs.

Introduction of society, Sociological imagination, the two revolutions and their socio-economic technological and scientific implications; Social significance of science and technology, ideas beyond technology.

Unit 2

12 Hrs.

Perspectives on relations between science and technology; Sociological perspective on scientific knowledge: Karl Marx, Emile Durkheim and Karl Mannhen's Sociology of knowledge; Merton's approach to science and technology.

Unit 3

12 Hrs.

Course Structure & Syllabus of B.Tech.– Petroleum Engineering

Applicable for Batch: 2021-25

Ethos of science, Matthew effect in science, Thomas theorem and Mathew effect; Thomas Kunn's notions paradigm and paradigm-based science, Scientific community and growth of scientific knowledge.

Unit 4

12 Hrs.

Science in India: science and technology policies in India, Scientific communities and their linkages, national and international Science, Ethics in science & engineering, environment and science and technology

COURSE OUTCOME:

TEXT BOOKS

1. Federic A. Lyman: Opening Engineering Students Mind to Idea to Ideas Beyond Technology. IEEE Technology and Society Magazine, Fall, pp.16-23. (2002)
2. John Theodore Rivers: Technology and the use of Nature. Technology in Society, 25(3), August, pp.403-416 (2003).

REFERENCE BOOKS

- Ronald R. Kline: Using History & Sociology to Tech Engineering Ethics. IEEE Technology and Society Magazine, Winter, pp.13-20 (2002).
- V.V. Krishna: A portrait of the scientific community in India: Historical Growth and Contemporary Problems, Gaillard et al. (eds). Scientific Communities in the Developing World, Sage (1997)

12. Teaching and Learning Strategy

All materials (ppts, assignments, labs, etc.) will be uploaded on online platform.

Course Structure & Syllabus of B.Tech.– Petroleum Engineering

Applicable for Batch: 2021-25

1. Department offering the course	School of Liberal Arts & Management
2. Course Code	LAF484
3. Course Title	Education and Social Change
4. Credits (L:T:P:C)	3:0:0:3
5. Contact Hours (L:T:P)	3:0:0
6. Prerequisites (if any)	NIL
7. Course Basket	Humanities & Liberal Arts

8. Course Summary

The course will help the students to take a significant action in area of education to maintain social change by knowing various education policies.

9. Course Objectives

- To define the various types of education policies
- To understand the role in striving for social change.
- To overview on education and its implications on social changes to the students

10. Course Outcomes

On successful completion of the course, students will be able to achieve the following:

- The students will understand how the education system assesses the importance of education in society.
- The student will be able to participate in the changes required in society.
- Education will be used as a tool to implement adequate changes in society.

11. Curriculum Content

Unit 1

9 Hrs

General introduction to the place of learning in society. Learning, education and training. Changing meanings of education across time and society. A brief historical perspective on education in India.

Unit 2

9 Hrs

Social-political arithmetic as a spurious way of understanding education and social change. Structural functionalist perspectives and structural-conflict perspectives on education

Unit 3

12 Hrs

Class, conflict, legitimation processes, reproduction of society. Anarchist perspectives. “New” Sociology of Education. Symbolic interactionist perspectives on education. Resistances to schooling. Critical theory and education.

Unit 4

9 Hrs

Course Structure & Syllabus of B.Tech.– Petroleum Engineering

Applicable for Batch: 2021-25

Neo-Weberian perspectives on education. Status politics and education. Caste, class, gender and education in India. Indian thinkers on education. Current debates on the place of education in India.

TEXT BOOKS

1. Desai, A.R. (2005), Social Background of Indian Nationalism, Popular Prakashan.
2. Giddens, A (2009), Sociology, Polity, 6th ed.

REFERENCE BOOKS

- Guha, Ramachandra (2007), India after Gandhi, Pan Macmillan.
- Sharma R.S. (1965), Indian Feudalism, Macmillan.
- Deshpande, Satish (2002), Contemporary India: A Sociological View, Viking.
- Gadgil, Madhav & Ramachandra Guha(1993), This Fissured Land: An Ecological History of India, OU Press.
- Haralambos M, RM Heald, M Holborn (2000), Sociology, Collins.
- Mohanty, M (ed.) (2004), Class, Caste & Gender- Volume 5, Sage.
- Dhanagare, D.N., Themes and Perspectives in Indian Sociology, Rawat

12. Teaching and Learning Strategy

All materials (ppts, assignments, labs, etc.) will be uploaded on online platform.

Course Structure & Syllabus of B.Tech.– Petroleum Engineering

Applicable for Batch: 2021-25

1. Department offering the course	School of Liberal Arts & Management
2. Course Code	LAF485
3. Course Title	Industrial Psychology
4. Credits (L:T:P:C)	3:0:0:3
5. Contact Hours (L:T:P)	3:0:0
6. Prerequisites (if any)	NIL
7. Course Basket	Humanities & Liberal Arts

8. Course Summary

This course provides the knowledge about application of psychological theories of industrial psychology and workplace environments. It also offers to identify the training and development needs in areas such as productivity, management and employee working styles and work environment.

9. Course Objectives

Student will able to understand how the science of human behavior is used to select, develop, and manage employees and organization. They will also learn how organizations create a supportive work environment to enhance the productivity of an industry. They will also able to learn group dynamics, organizational culture and principle for effective organization.

10. Course Outcomes

On successful completion of the course, students will be able to achieve the following:

- a. The students will be able to understand basic concepts of industrial psychology
- b. The students will be able to apply the fundamentals of industrial psychology for organization effectiveness.
- c. The students will learn about the organizational best practices and strategies.
- d. After completing this course student will develop and learn the fundamental of industrial psychology in understanding organizational effectiveness.
- e. They will also learn how organizations culture and practices creates a conducive environment to enhance the productivity of an industry.

Unit 1: Introduction to Industrial Psychology

Definitions, History & Nature & Scope of Industrial Psychology, Role of Industrial Psychology, Organizational Development

Unit 2: Motivation and Work Behavior

Course Structure & Syllabus of B.Tech.– Petroleum Engineering

Applicable for Batch: 2021-25

Motivation & work behavior. (Theory X and Y, McClelland's, Need Theory, Herzberg's Two Factor Theory, Cultural Differences in Motivation, Groups & work teams, Group Behavior, Group formation & development

Unit 3: Organizational Culture and Leadership

Functions of organizational culture, Organizational Socialization, Assessing Cultural Values and Fit, Cross Cultural issues, Influence of Organizational Culture on Employees, Leadership vs Management, Leadership Theories, Emerging issues in Leadership

Unit 4: Performance and Stress Management

Planning and Monitoring, Best Practices in Performance management, Training and Evaluation, Method of Performance appraisal, Work Stress and Mental Health, Time and Conflict Management

11. Curriculum Content

Textbook(s)

Spector, P.E. (2016). Industrial and Organizational Psychology: Research and Practice. New Delhi: Wiley.

Reference Books

- Blum & Naylor (1982) Industrial Psychology. Its Theoretical & Social Foundations CBS Publication.
- Aamodt, M.G. (2007) Industrial/Organizational Psychology: An Applied Approach (5th edition) Wadsworth/ Thompson: Belmont, C.A.
- Aswathappa K. (2008). Human Resource Management (fifth edition) New Delhi: Tata McGraw Hill.
- Robbins, S.P. & Sanghi, S. (2009). Organizational behavior (11th ed.). New Delhi: Pearson Education.
- Schultz, D. and Schultz, S. E. (2006). Psychology and work today. 8th ed. N.D.: Pearson Education

12. Teaching and Learning Strategy

All materials (ppts, assignments, audio and videos etc.) will be uploaded on online platform.

Course Structure & Syllabus of B.Tech.– Petroleum Engineering

Applicable for Batch: 2021-25

1. Department offering the course	School of Liberal Arts & Management
2. Course Code	LAF486
3. Course Title	Innovation and Entrepreneurship
4. Credits (L:T:P:C)	3:0:0:3
5. Contact Hours (L:T:P)	3:0:0
6. Prerequisites (if any)	NIL
7. Course Basket	Humanities & Liberal Arts

8. Course Summary

The purpose of Entrepreneurship & Innovation is to develop students for work in a sector of the entrepreneurial and/or innovative professions.

9. Course Objectives

1. The students will gain strategic understanding of entrepreneurship and innovation.
2. The students will assess the interdependent, fast-changing, and diverse world of entrepreneurship and innovation.
3. The students will be able to effectively communicate using business specific terminology in written and verbal form and facilitate information flow in a variety of organizational, social, and intercultural contexts.

10. Course Outcomes

On successful completion of the course, students will be able to achieve the following:

1. The student will be able to develop captivating products and services to solve challenging problems in a highly uncertain environment, often under considerable time constraints with very limited resources.
2. The students will develop advanced knowledge on how to assess business opportunities and an in-depth understanding of what typically characterize successes and failures.

11. Curriculum Content

Unit 1: Introduction to Entrepreneurship

Entrepreneurs; entrepreneurial personality and intentions - characteristics, traits and behavioral; entrepreneurial challenges. Entrepreneurial Opportunities: Opportunities. discovery/ creation, Pattern identification and recognition for venture creation: prototype and exemplar model, reverse engineering.

Unit 2: Entrepreneurial Process and Decision Making

Entrepreneurial ecosystem, Ideation, development and exploitation of opportunities; Negotiation, decision making process and approaches, Effectuation and Causation.

Unit 3: Crafting business models and Lean Start-ups

Course Structure & Syllabus of B.Tech.– Petroleum Engineering

Applicable for Batch: 2021-25

Introduction to business models; Creating value propositions-conventional industry logic, value innovation logic; customer focused innovation; building and analyzing business models; Business model canvas, Introduction to lean startups, Business Pitching.

Unit 4: Organizing Business and Entrepreneurial Finance

Forms of business organizations; organizational structures; Evolution of Organization, sources and selection of venture finance options and its managerial implications. Policy Initiatives and focus; role of institutions in promoting entrepreneurship.

12. TEXT BOOKS

1. Enterprise and small business- Principal Practice and Policy, S. Carter and D. Jones-Evans, Pearson Education, 2006.
2. Technology Ventures: From Idea to Enterprise, T. H. Byers, R. C. Dorf, A. Nelson, McGraw Hill, 2013.

13. REFERENCE BOOKS

1. A Business Model of Entrepreneurship Verstraete, T. and Laffitte, E.J., Edward Elgar Publishing, 2011.
2. Start-up sutra: what the angels won't tell you about business and life, Prasad Rohit, Hachette India, 2013.

14. Teaching and Learning Strategy

All materials (ppts, assignments, labs, etc.) will be uploaded on online platform.